

WESTERN AVIONICS

**MIL-STD-1553 VXI (MATE-CIIL)
INTELLIGENT INTERFACE BOARD**

P/N 1U10905G04 Rev A

**User Manual
UM 10905M Rev A**

**© Western Avionics Ltd.
13/14 Shannon Free Zone
Co. Clare
Ireland**

21 October 1998

TABLE OF CONTENTS

1	CHAPTER 1	7
	GENERAL INFORMATION	7
1.1	INTRODUCTION	7
1.2	MANUAL DESCRIPTION	7
1.3	CAPABILITIES	8
1.3.1	General	8
1.3.2	Bus Controller (BC)	8
1.3.3	Multi-Remote Terminal (RT)	9
1.3.4	Bus Monitor (BM)	10
1.3.5	Error Generation and Detection	10
1.4	FEATURES	11
1.5	SYSTEM CHARACTERISTICS AND SPECIFICATIONS	12
1.6	LIST OF FURNISHED ITEMS	14
1.7	LIST OF RELATED PUBLICATIONS	14
1.8	STORAGE DATA	14
1.9	TOOLS AND TEST EQUIPMENT	14
1.10	SAFETY PRECAUTIONS	14
2	CHAPTER 2	15
	INSTALLATION AND PREPARATION FOR USE	15
2.1	GENERAL	15
2.2	INSTALLATION OF SURETEST 2704	15
2.2.1	Logical Address Setting	15
2.2.2	Linker Block LK1	15
2.2.3	Installation into VXI Rack	16
2.3	TURN ON	16
2.4	SELFTEST	16
2.5	RESET	16
2.6	PINOUTS	17
3	CHAPTER 3	18
	OPERATION	18
3.1	INTRODUCTION	18
	Section I, Theory of Operation	18
3.2	GENERAL	18
3.3	OVERALL FUNCTIONAL DESCRIPTION	18
3.3.1	Bus Controller	19
3.3.2	Multi-Remote Terminal	19
3.3.3	Bus Monitor	20
3.4	MATE CIIL LANGUAGE CAPABILITY	21
3.5	ALTERNATE LANGUAGE CAPABILITY	21
3.6	USING THE BUS CONTROLLER	21
3.6.1	Introduction	21
3.6.2	Word Count Selection	21
3.6.3	Secondary Command (RT-RT)	22
3.6.4	Data Word Entry	22
3.6.5	Data Word Errors	22
3.6.6	Trigger Pulse Out	22
3.6.7	Superseding Command	22
3.6.8	Bus Controller Link Page	22
3.6.9	Transmit	22

3.7	USING THE MULTI-REMOTE TERMINALS -----	23
3.7.1	<i>RT Page/Sub Page Description</i> -----	23
3.7.2	<i>The Master Page</i> -----	24
3.7.3	<i>Sub Pages</i> -----	25
3.8	USING THE BUS MONITOR -----	25
3.8.1	<i>Introduction</i> -----	25
3.8.2	<i>Trigger Condition</i> -----	26
3.8.3	<i>64KByte DRAM Buffer Operation</i> -----	27
3.9	SAWTOOTH / RANDOM FUNCTION -----	28
3.9.1	<i>Introduction</i> -----	28
3.9.2	<i>Superseding Command</i> -----	28
3.10	DRAM OPERATION -----	29
Section II, Operating Instructions -----		30
3.11	INTRODUCTION -----	30
3.12	SET UP BUS CONTROLLER -----	30
3.13	SUPERSEDING COMMANDS -----	36
3.14	SET UP REMOTE TERMINAL -----	38
3.15	SET UP BUS MONITOR -----	42
3.16	LOAD AND RUN BC, RT OR BM -----	46
3.17	HALT BC, RT OR BM -----	47
3.18	TRANSMIT BUS MONITOR STACK -----	48
3.19	TRANSMIT MONITOR EOTD -----	49
3.20	DOWNLOAD DATA TO DRAM -----	50
3.21	EXECUTE USER PROGRAM -----	50
3.22	STATUS REPORTING -----	51
3.22.1	<i>Status Byte Register</i> -----	52
3.22.2	<i>Service Request Enable Register</i> -----	52
3.22.3	<i>Request True Generation</i> -----	53
3.22.4	<i>Standard Event Status Register</i> -----	53
3.22.5	<i>Standard Event Status Enable Register</i> -----	54
3.22.6	<i>Error Queue</i> -----	54
3.23	COMMON COMMANDS -----	54
3.23.1	<i>*CLS Command</i> -----	54
3.23.2	<i>*ESE Command</i> -----	54
3.23.3	<i>*ESR? Command</i> -----	55
3.23.4	<i>*IDN? Command</i> -----	55
3.23.5	<i>OPC Command</i> -----	55
3.23.6	<i>*STB? Command</i> -----	55
3.23.7	<i>*WAI Command</i> -----	56
3.24	CHANGE OPERATING MODE -----	56
3.25	FRAME RELATED COMMANDS -----	57
3.26	CONFIGURATION COMMANDS -----	66
3.26.1	<i>ERR? Command</i> -----	66
3.26.2	<i>Error Numbers and Descriptions</i> -----	67
Section III, Worked Application Examples -----		68
3.27	INTRODUCTION -----	68
3.28	PROGRAM EXAMPLE -----	68
Appendix A, Default Modes Codes Responses, 1553A -----		71
Appendix B, Default Mode Code Responses, 1553B -----		72
Appendix C, MIL-STD-1553B Assigned Mode Code Responses -----		73
SP-J-403-E-1043 EFA Stanag 3838 Protocol Implementation (BC) -----		73
SP-J-403-E-1044 EFA Stanag 3838 protocol Implementation (RT) -----		73
Appendix D, Bus Controller, Bus Monitor enhancements and Specialised Selective Capture -----		74

4	BUS CONTROLLER, BUS MONITOR AND SSC ENHANCEMENTS, INTRODUCTION	75
4.1	APPLICABILITY	75
4.2	IMPLEMENTATION	75
4.3	BUS CONTROLLER ENHANCEMENTS	75
4.3.1	<i>DB Command</i>	75
4.3.2	<i>I1 Command</i>	76
4.3.3	<i>LB Command</i>	76
4.3.4	<i>Error Reporting</i>	77
5	BUS MONITOR ENHANCEMENTS	77
5.1	I2 COMMAND	77
5.2	DS? COMMAND	78
5.3	DD? COMMAND	78
5.4	DQ? COMMAND	79
5.5	ERROR REPORTING	79
6	DISABLING THE ENHANCEMENTS	79
7	PROGRAMMING CONSIDERATIONS	79
8	SPECLALISED SELECTIVE CAPTURE (SSC)	80
9	SSG IMPLEMENTATION	80
10	BUS MONITOR ENHANCEMENTS	80
10.1	ST COMMAND	81
10.2	S1 COMMAND	81
10.3	SQ? COMMAND	82
10.4	S0 COMMAND	82
11	PROGRAMMING CONSIDERATIONS	82
12	WORKED EXAMPLES	83
Appendix E, 1553 Data Bus Connections		85
13	1553 DATA BUS CONNECTIONS	86
APPENDIX F, CONTROL INTERFACE INTERMEDIATE LANGUAGE (CIIL) \L 5		90
GENERAL INFORMATION		91
14	CIIL DEFINITIONS AND SYNTAX	92
14.1	NOTATION KEY	92
14.2	MODE DESIGNATORS, NOUN MODIFIERS AND OPERATIONAL (OP) CODES	92
14.3	DATA FORMATS	96
14.4	MESSAGE-ERROR-MASK	96
14.5	MONITOR TRIGGER ERRORS	97
14.6	GAP TIME	97
14.7	RESPONSE TIME	97
15	SURETEST CIIL INSTRUCTIONS	98
15.1	INTRODUCTION	98
15.2	SYNTAX	98
15.3	INPUT COMMANDS TO THE SURETEST	103
15.4	COMMANDS THAT GENERATE SURETEST RESPONSES	110
15.5	RESPONSE MESSAGES	113

16	PROGRAMMING SURETEST (CIIL INSTRUCTIONS)	-----115
16.1	INTRODUCTION	-----115
16.2	ALTERNATIVE LANGUAGE	-----115
16.3	ERROR BIT POSITIONS	-----115
16.3.1	<i>Data formats.</i>	-----115
16.3.2	<i>Retrieved Messages</i>	-----116
16.3.3	<i>Monitor Triggers</i>	-----116
16.4	PROGRAM EXAMPLES	-----116
16.4.1	<i>Sample CIIL program #1</i>	-----117
16.4.2	<i>Sample CIIL program #2</i>	-----119
16.4.3	<i>Sample CIIL program #3</i>	-----121

Table of Figures & Tables

Table 1-1	Error Generation and Detection Capability	11
Figure 1-1	SURETEST 2701 & 2704 Front Panel	13
Figure 2-1	Pinouts for 1553 Bus connectors	17
Figure 3-1	SURETEST 2704 Block Diagram	20
Figure 3-2	RT Structure	23
Figure 3-3	Superseding Command Timing	28
Figure 3-4	Top Level Syntax Diagram	31
Figure 3-5	Remote Terminal Set up Syntax Diagram	32
Figure 3-6	Superseding Command Set-up Syntax Diagram	37
Figure 3-7	Remote terminal Set up Syntax Diagram	39
Figure 3-8	Bus Monitor Setup Syntax Diagram	43
Figure 3-9	Load/Run BC, RT, BM Syntax Diagram	46
Figure 3-10	Halt BC, RT, BM Syntax Diagram	47
Figure 3-11	Download to DRAM Syntax Diagram	50
Figure 3-12	Status Reporting Structure Diagram	51
Figure 3-13	Change Operating Modes Syntax Diagram	56
Figure 3-14	Example BC Page 001 (part 1)	68
Figure 3-15	Example RT 08 (part 1)	69
Figure 3-16	Example Bus Monitor Trigger Condition	70
Figure 13-1	1553 Bus Interface	86
Figure 13-2	Bench testing Transformer Coupled Device	87
Figure 13-3	Bench testing Direct Coupled Stub on 1553 device	87
Figure 13-4	Replacement of RT/BC (but not the coupler box) in an existing system	88
Figure 13-5	Replacement of RT/BC and coupler box in an existing system	88
Figure 13-6	Monitoring of an External System	89
Table 14-1	CIIL Instructions	93
Table 15-1	Syntax	99
Table 15-1	Syntax (Continued)	100
Table 15-2	Syntax - Set Code	100
Table 15-2	Syntax - Set Code (Continued)	101

GENERAL INFORMATION

1.1 INTRODUCTION

The SURETEST 2701/2/3 cards are message based VXI "C" sized modules, providing an intelligent and powerful interface that allows the system controller to communicate with, and test devices built in compliance with MIL-STD-1553A/B serial digital data bus, as used in many military aircraft and communications systems. Each card provides the user with three totally independent functions that may be run simultaneously, and these are:

- A 1553 Bus Controller (BC) Simulator.
- A 1553 single or multiple Remote Terminal (RT) Simulator.
- A 1553 Bus Monitor (BM) and Analyser.

SURETEST 2701/2/3 are programmed by sending ASCII characters or ASCII characters combined with decimal or hexadecimal data from the system controller. Data is returned to the system controller as ASCII characters with hexadecimal data. As SURETEST 2701/2/3 are similar except where noted, only the instructions for the operation of SURETEST 2701 are described in this manual.

1.2 MANUAL DESCRIPTION

The following paragraphs provide a general description of the manual layout and content:

- **Chapter 1** **General Information** - contains a brief description of the manual, and a general description of the SURETEST 2701. This chapter also contains the instrument specifications, information concerning accessories, furnished items and safety precautions.
- **Chapter 2** **Installation and Preparation for Use** - contains instructions on installation, preparation for use, self-test and reset of the SURETEST 2704.
- **Chapter 3** **Operation** - contains a functional description of the SURETEST 2704 and operating procedures necessary to run SURETEST 2704. This chapter is divided into three sections as follows; Section I Theory of Operation, Section II Operating Instructions, Section III Worked Applications Examples.
- **Appendix A** **Default Mode Code Response for MIL-STD-1553** - contains a list of the default mode code responses for 1553A.
- **Appendix B** **Default Mode Code Responses for MIL-STD-1553** - contains a list of the default mode code responses for 1553B.
- **Appendix C** **MIL-STD-1553B Standard Assigned Mode Code Responses** - contains information on the Standard 1553B Mode Codes and their implementation.
- **Appendix D** **Bus Controller, Bus Monitor Enhancements and Specialised Selective Capture (SSC)** - contains information on enhanced dynamic updating of the Bus Controller and Bus Monitor messages. Also included is information on enhancements that provide SSC capability in the Bus Monitoring mode of operation.
- **Appendix E** **1553 Data Bus Connections** - contains information on SURETEST 2704, 1553 data bus connections.

1.3 CAPABILITIES

1.3.1 General

In the Bus Controller simulation mode, SURETEST 2704 can communicate with any or all of the 32 Remote Terminals (31 plu9 broadcast mode) as defined by MIL-STD-1553A/B. Message sequence lists and data lists for each RT to be addressed may be stored on the card, or transmitted from the system controller, and these then transmitted to the proper RT(s).

All response data from the RT(s) is stored in on-card memory.

In the Remote Terminal simulation mode, SURETEST 2704 can emulate any or up to 32 RT's. Appropriate response data and status words for each emulated RT may be preloaded to the card, or downloaded from the system controller. All response data from the emulated RT(s) is stored in on-card memory.

In Bus Monitor mode SURETEST 2704 stores all bus traffic with comprehensive time tagging information, for later evaluation.

SURETEST 2704 can introduce errors into the transmitted data stream, including parity, Manchester encoding, dropped data bits, inter-word gaps, incorrect or invalid sync patterns, incorrect RT response time, incorrect number of bits per word and words per message, and on incorrect or both buses. Output amplitude, inter-message gap times, and no response timeouts are programmable. Received data can be screened for errors in parity, Manchester coding, dropped data bits, bit count, incorrect sync, terminal/controller response time, inter-word data gap, word count and message format errors such as incorrect terminal address, missing RT response, invalid status words and invalid mode code or broadcast usage.

1.3.2 Bus Controller (BC)

RAM storage of 96Kbytes are provided for command sequence and response data. All bus transfer types are supported including RT-RT transfers, and superseding commands. Full frame timing, both variable and fixed frame are available with minimal set up requirements.

Transmission: Up to 401 unique messages of 1 command word, and up to 33 data words (32 + 1 error word) can be transmitted between 1 and 59999 times, or on a continuous basis on either primary or secondary bus, or for error condition, both buses. Up to 30000 link pages are available to either allow the user to enter sequenced lists of messages in both free running and fixed frame formats. The number of minor cycles within each frame and messages per minor cycle are fully programmable. Fixed frame times are programmable from 1 to 65mS, in 1mS intervals.

Amplitude Level: Programmable from 0 to 20 volts, in 1 volt increments.

Inter-message Gaps Programmable from 8us (10us in 1553B mode) to 30000us, in 1us steps, and from 1 to 3000mS, in 1mS increments.

Time-outs: Programmable to 1us resolution in the range 10 (14) to 59,999us, in 1553A/B modes.

External Trigger: SURETEST 2704 and SURETEST 2702 provide an event triggering pulse for external use. SURETEST 2703 accepts external trigger for frame synchronisation with external event.

1.3.3 Multi-Remote Terminal (RT)

RAM storage of 96Kbytes is provided, allowing simulation of any number of RT address and sub-address combinations up to the maximum permissible. Responses to all mode codes, illogical, and illegal messages may be programmed. Full MIL-STD-1553A/B protocol error injection and generation capabilities are provided.

<i>RT Addresses:</i>	Up to 32 (31) RT addresses per 1553A/B are programmable at all sub-addresses.
<i>RT Sub-Addresses:</i>	Any 20 sub-addresses can be allocated a unique 33-word data block.
<i>Response Amplitude:</i>	Programmable from 0 to 20 volts, in 1 volt intervals.
<i>Response Time:</i>	Programmable from 4 to 99us (2 to 97us in 1553A mode)
<i>Mode Codes:</i>	All default mode codes for 1553A/B are available, and may be reassigned to either dynamic bus control, reply with just status, reply with status and data word, transmit last command, and reserved, as required.
<i>Data Words:</i>	Programmable for normal hexadecimal data or to change on subsequent transmissions to pseudo-random values, or one of three independently programmable saw-tooth functions with definable lower and upper limits, with positive or negative step values of between 0000 to FFFF hex.
<i>RT-RT Transmission:</i>	Supported for any RT.
<i>Dynamic Bus Control Mode Code:</i>	Dynamic Bus Control acceptance bit automatically set.
<i>RT Message Error Bit:</i>	Automatically set on receipt of an invalid or illegal message.
<i>Broadcast Bit:</i>	Set on detection of any valid broadcast command.

1.3.4 Bus Monitor (BM)

The Bus Monitor is capable of monitoring all bus activity on both primary and secondary buses. RAM storage of 64Kbyte is provided, allowing for storage of up to 10921 bus words all with error and timing data. The Bus Monitor may be used in three basic modes of operation, for continuous capture of all bus activity, for event triggered modes of operation and for selective capture. SURETEST 2704 may be armed by an external hardware trigger on a specific word type, word content, data word, status word, status message error bits, or the second command of an RT-RT transfer. Word content trigger is available as a 16-bit trigger. Error trigger is available from errors in terminal address, Manchester, parity code, wrong bus, both buses, no response, word count, long word, short word, and slow response. Multiple errors may also be selected. An enlarged buffer of up to 881KBytes of RAM storage is available when used in specialised selective capture mode.

No Response Time-Out: Programmable between 10 (14) and 59999us, in 1us steps for 1553A/B modes.

Trigger Points: Pre and post trigger count of up to 10,921 words, with post-trigger adjustable between 1 and 10,921 words.

Triggering: Word type (command, data, status, status bit set or the second word of an RT-RT transfer).
Any defined 16-bit word.
Terminal address error.
Manchester code error.
Parity error.
Transmit on both buses.
Transmit on wrong bus.
No response.
Word count error.
Long word or short word.

Selective Capture: Records occurrences of data for a defined command word only.

Specialised Selective Capture- Mode 1: Data filtered to command word mask, status word mask, error filter, and stored in enlarged buffer. (Refer Appendix D, para. D-5).

Specialised Selective Capture - Mode 2: Six triggers with definable trigger word mask and trigger error mask allowing up to 9999 occurrences of each trigger type to be stored in A24 memory. (Refer to Appendix D, paragraph D-9).

1.3.5 Error Generation and Detection

Errors of the following types can be introduced into the transmitted data stream:

Parity, Manchester encoding, dropped data bits, inter-word data gaps, incorrect or invalid sync patterns, incorrect RT response time, incorrect number of bits per word and words per message, and on incorrect, or both buses.

Received data can be screened for errors in the following

Parity, Manchester coding, dropped data bits, bit count, incorrect sync, terminal/controller response time, inter-word data gap, word count, and message format errors such as incorrect terminal address, missing RT response, invalid status words, and invalid mode code or broadcast usage.

Global variables for output amplitude, inter-message gap times, and no response timeouts are programmable. Refer to table 1-1 for error generation and detection capabilities.

Table 1-1 Error Generation and Detection Capability

ERROR TYPE		BC	MRT	BM
WORD	Word type	X	X	X
	Incorrect sync	X	X	X
	Manchester	X	X	X
	Parity	X	X	X
	Long word	X	X	X
	Short word	X	X	X
MESSAGE	Terminal Address		X	X
	Too many words	X	X	X
	Too few words	X	X	X
BUS	Wrong bus	X	X	X
	Both buses	X	X	X
RESPONSE	No response		X	X
	Slow response		X	X
VARIABLES	Output voltage	X	X	
	RT response		X	
	Inter-message gap	X		
	No response time-out	X		X

1.4 FEATURES

The features of the SURETEST 2704/2/3 are as follows:

- VXI (Rev.1.3 of VXI Specification).
- Message Based.
- Single Slot, "C" Size Card.
- A16/A24 Master Capability.
- D 16 Data Transfer.
- 1553A/B or McAir 3818 Capability.
- Built in Test (BIT).
- Dual Redundancy.
- Multiple Error Generation and Detection per Word and Message.
- RT-RT Transfer.
- External Monitor Trigger-In.
- External Frame Sync-In (Model 2703 only).
- BC Gate Output (Models 2701/2702).
- 64K BM Stack Accessible as A24 Memory from VXI bus.

1.5 SYSTEM CHARACTERISTICS AND SPECIFICATIONS

The characteristics and specifications of SURETEST 2701/2/3 are listed as follows:

- **VXI Specifications**
 - Device Type: VXI Message Based Instrument.
 - Protocol: Word Serial.
 - Module Size: "C" size, one slot wide.
- **VXI Compatibility:** Conforms to Revision 1.3 of VXI specification for message based instruments.
- **BITE:** 87% Confidence Level.
- **Weight:** 2.4kg (4.01bs). |
- **Power + 5Vdc**
 - 3.8A max.
 - +12Vdc 100mA max.
 - 12Vdc 50mA max.
- **Cooling Requirements:** (For 10°C temperature rise at maximum load)
 - Airflow: 1.94 l/s
 - Backpressure: 0.2 mm H₂O
- **Temperature:**
 - Operating: 0°C to +40°C
 - Non-operating: -20°C to +70°C
- **Humidity:**
 - 0°C to +29°C: 95% RH
 - 30°C to +40°C: 75% RH
- **Mean Time Between Failure (MTBF) per MIL 217E:**

Hours	Temp.	Category
108,932	20°C	GB (Ground Benign)
46,809	40°C	GB
78,338	20°C	GMS (Ground Mobile Sheltered)
40,043	40°C	GMS
27,005	20°C	GF (Ground Fixed)
20,247	40°C	GF
15,410	20°C	GM (Ground Mobile)
12,827	40°C	GM
- **Front Panel Connectors**
 - Trig Out: Co-axial type CBBJR29
 - Trig In: Co-axial type CBBJR29
 - Sec Stub: Tri-axial type CBBJR79
 - Sec Bus: Tri-axial type CBBJR79
 - Sec Term: Tri-axial type CBBJR79
 - Pri Stub: Tri-axial type CBBJR79
 - Pri Bus: Tri-axial type CBBJR79
 - Pri Term: Tri-axial type CBBJR79
- **LED Indicators**
 - FAIL Shows Status of Selftest
 - RDY System Ready for Operation
 - TX Bus Traffic Present
 - MON Bus Monitor Enabled
- **Front Panel Switch:** Bus Terminator In/Out.

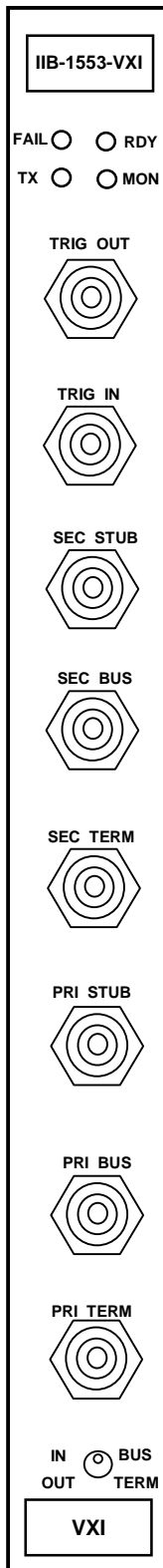

Figure 1-1 SURETEST 2701 & 2704 Front Panel

1.6 LIST OF FURNISHED ITEMS

The following is a list of furnished items:

1. Bus Analyser/Simulator, SURETEST 2701/2/3
2. Users Manual UM 109050 Revision A (This document)

1.7 LIST OF RELATED PUBLICATIONS

The following is a list of related publications:

1. IEEE-STD-488.1
2. MIL-HDBK-1553
3. MIL-STD-1553

1.8 STORAGE DATA

As SURETEST contains electrostatic sensitive devices (ESDs), special storage and handling is required. DO NOT store near electrostatic, electromagnetic, magnetic or radiation fields.

1.9 TOOLS AND TEST EQUIPMENT

No special tools or test equipment are required to test the SURETEST 2701/2/3.

1.10 SAFETY PRECAUTIONS

Operating personnel must observe safety regulations at all times, refer to the Safety Summary at the front of this manual.

WARNING

Potentially hazardous voltages exist on the rack power supply. Do not attempt to remove SURETEST 2704 without first removing mains power. Improper handling can cause injury or death.

INSTALLATION AND PREPARATION FOR USE

2.1 GENERAL

On delivery, inspect the unit for possible damage. If it is damaged, return to the transport company, for return to distributor. When unpacking remove all protective covering and store covering, as unit may need to be reshipped at a later date.

CAUTION

SURETEST contains Electrostatic Sensitive Devices (ESD's). Special handling is required, do not ship or store near electrostatic, electromagnetic, magnetic or radioactive fields.

2.2 INSTALLATION OF SURETEST 2704

Prior to installing SURETEST 2704 into VXI rack the following settings must be made to the SURETEST 2704 Board.

2.2.1 Logical Address Setting

The logical address is set by a DIL switch, accessible via a hole on the module cover. A switch in the ON position sets the bit to zero (0).

- Switch position 1 corresponds to D0 of logical address
- Switch position 2 corresponds to D1 of logical address
- Switch position 3 corresponds to D2 of logical address
- Switch position 4 corresponds to D3 of logical address
- Switch position 5 corresponds to D4 of logical address
- Switch position 6 corresponds to DS of logical address
- Switch position 7 corresponds to D6 of logical address
- Switch position 8 corresponds to D7 of logical address

Dynamic Configuration is not selected.

2.2.2 Linker Block LK1

Linker Block LK1 selects REQ/GNT level and is accessible only by removing module side cover. The default setting is level 3 in compliance with VXI specification Rev. 1.3.

Permissible Settings are as follows:

1-24	2-23	3-22	4-21
5-20	20-19	20-19	20-19
6-19	7-18	18-17	18-17
18-17	8-17	9-16	16-15
16-15	16-15	10-15	11-14
14-13	14-13	14-13	12-13
Level 0 Used	Level 1 Used	Level 2 Used	Level 3 Used (DEFAULT)

2.2.3 Installation into VXI Rack

Ensure that all power has been removed from the rack before inserting the SURETEST 2704 board into a VXI rack.

2.3 TURN ON

Set mains power to VXI rack to ON. SURETEST 2704 will perform system selftest on the BC, MRT and BM lasting approximately four seconds. When selftest passes, the RED led extinguishes. When the Resource Manager has instructed the instrument to begin normal operation then the RDY led lights. If selftest fails then the RED led remains lit.

2.4 SELFTEST

After applying power to the VXI rack or after pressing the rack RESET switch, system selftest will be performed. SURETEST 2704 will perform a system selftest that tests the Bus Controller, Multi-Remote Terminal and Bus Monitor lasting approximately four seconds. If selftest fails then the RED led on the front panel remains lit. If selftest passes then the RED led is extinguished, and GREEN RDY led is lit.

2.5 RESET

After power-up/reset the 68000 processor writes default data to each of the functional areas of the board (BC, MRT and BM) as follows:

- **Bus Controller Default Conditions:**

Pages 001-320 of the Bus Controller will have the following defaults:

Bus	Primary
Amplitude	10V
IMG	1000us
BTO	14us
Command	01 R 01 01
RT-RT Command	0 R 00 01
Data	Data words 1 - 33 will have data 1H - 20H respectively
Link Pages	001
Errors	None

- **MRT Default Conditions:**

All RTs and sub addresses will be disabled.

Amplitude	10V
Response Time	4us
Status	RT address with all other bits cleared
Mode Codes	See Appendices A, B and C
Data	Data words 1 - 33 will have data 1H - 20H respectively
Errors	None

- **Bus Monitor Default Condition:**

Trigger-On	Anything
------------	----------

2.6 PINOUTS

Pin-out of the MIL-STD-1553 bus connectors are as shown below:

CONNECTION	DESCRIPTION
Centre conductor	Differential 1553 signal (+)
First shield	Differential 1553 signal (-)
Outer shield	Ground

Figure 2-1 Pinouts for 1553 Bus connectors

CHAPTER 3

OPERATION

3.1 INTRODUCTION

This chapter contains the theory of operation and the operator instructions of the SURETEST 2704, also included are worked applications. The chapter is divided into three sections as follows:

- **Section I** Theory of Operation contains the functional description and block diagram of the SURETEST 2704 board.
- **Section II.** Operator Instructions contains complete operating instructions for the SURETEST 2704 board.
- **Section III.** Worked Applications Examples contains example word serial protocol command strings.

SECTION I. THEORY OF OPERATION

3.2 GENERAL

The SURETEST 2704 tests and emulates systems utilising the MIL-STD-1553 digital data bus. It can emulate the Bus Controller, Bus Monitor, or any number of Remote Terminals of the 1553 system. Up to 31 UUT's may be connected, via the MIL-STD-1553 bus, to SURETEST which will emulate the rest of that system in any configuration programmed by the operator. The Bus Analyser/Emulator can be programmed either by an operator or by a host computer. It can provide stimuli for up to 31 UUT's, monitor and capture data and responses from these UUT's for analysis. An overall block diagram (figure 3-1) of the SURETEST system is given, along with a brief explanation of each block.

3.3 OVERALL FUNCTIONAL DESCRIPTION

This paragraph gives an overall functional description of the SURETEST 2704. Refer to figure 3-1 SURETEST 2704 Block Diagram.

68000 Central Processor Unit (CPU)

The central processing unit (CPU) is a standard 68000 and is the main control element of SURETEST. It has the system firmware on board and interprets word serial protocol (WSP).

EPROMS

The erasable programmable read only memory devices (EPROMS) contain the system firmware. The firmware resides in 128Kbytes of EPROM and uses up to 1Mbyte DRAM. They are accessed by the 68000 and contains the program which runs the system.

Interrupt Controller

The interrupt controller is memory mapped by the 68000 and has seven levels of priorities for interrupts. The interrupt controller controls the interrupts from the Bus Controller, Bus Monitor and VXI interface.

DRAM

There is one megabyte of dynamic random accessed memory (DRAM) in the CPU and it is used for general program variables and storage of VXI commands. Part of the memory can be used for downloading of user programs.

3.3.1 Bus Controller

The Bus Controller can both transmit and receive information to/from the 1553 bus. The 96Kbytes of memory is used to store the setup messages, data, inter-message gaps for the Bus Controller. This static RAM is dual ported with access for both the 68000 CPU and Bus Controller signal processor (TMS320E15). This allows the CPU to change the set-ups while the Bus Controller is running.

Bus Controller Signal Processor

The Bus Controller signal processor is a TMS320E15 containing 4K words of EPROM. It accesses the static RAM when the 68000 is not doing so (this gives the dual ported property). All operations on signals coming from and going to the 1553 bus are controlled by a program stored in the EPROM on the TMS320E15. It can instruct which bus to transmit on, or which errors to generate depending on the setup defined.

1553 Logic and Error Injection

The Bus Controller transmit logic is based around a micro-sequencer which generates the 1553 signals and is capable of adding the required error injection under the control of the Bus Controller signal processor. The digital signals are converted to 1553 levels with programmable amplitude by a special purpose hybrid microcircuit. The Bus Controller signal processor interfaces to a DAC to determine the amplitude of the 1553 bus signal.

Static Ram

The static read only memory (SRAM) is dual ported, as it can be accessed by either the 68000 CPU or the onboard signal processor, TMS320E15.

Dual Ported Control Circuit

The circuit controls which processor has access to the static RAM. When the 68000 is busy elsewhere the TMS320E15 accesses information in the SRAM.

3.3.2 Multi-Remote Terminal

The Multi-Remote Terminals can both transmit and receive information to/from the 1553 bus. The Multi Remote Terminals can simulate all 31 RT addresses (32 when in 1553A operation) as well as any 20 of 30 sub addresses (31 when in 1553A operation) and can completely simulate any Remote Terminal.

Multi-Remote Terminal Signal Processor

The Multi-Remote Terminals signal processor is a TMS320E15 containing 4K words of EPROM. It accesses the static RAM when the 68000 is not doing so (this gives the dual ported property). All operations on signals coming from and going to the 1553 bus are controlled by a program stored in the EPROM on the TMS320E15. It can instruct which bus to transmit on, or which errors to generate depending on the setup defined.

1553 RT/Tx Logic and Error Injection

The Remote Terminal(s) transmit logic is based around a micro-sequencer which generates the 1553 signals and is capable of adding the required error injection under the control of the Remote Terminal(s) signal processor. The digital signals are converted to 1553 levels with programmable amplitude by a special purpose hybrid microcircuit. The Remote Terminal(s) signal processor interfaces to a DAC to determine the amplitude of the 1553 bus signal.

Static Ram

The static read only memory (SRAM) is dual ported, as it can be accessed by either the 68000 CPU or the onboard signal processor, TMS320E15.

Dual Ported Control Circuit

The circuit controls which processor has access to the static RAM. When the 68000 is busy elsewhere the TMS320E15 accesses information in the SRAM.

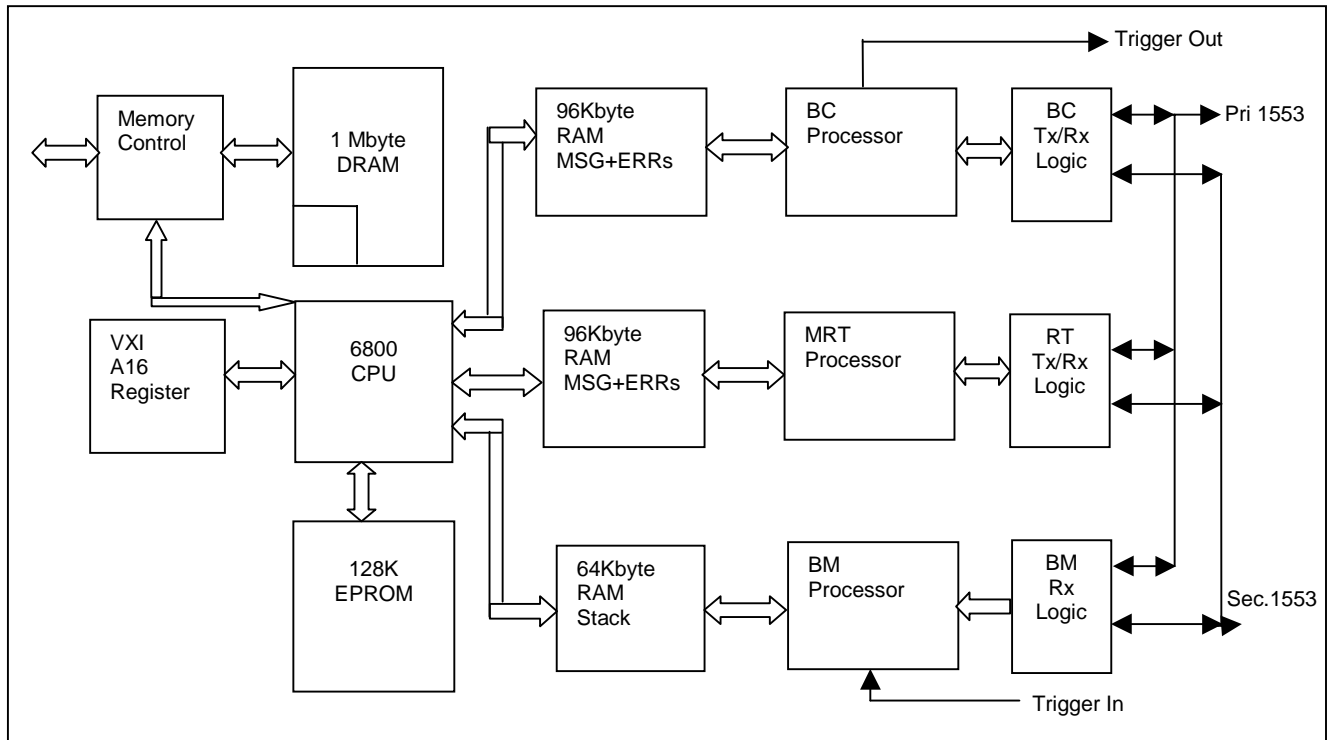

Figure 3-1 SURETEST 2704 Block Diagram

3.3.3 Bus Monitor

The Bus Monitor can only receive information from the 1553 bus and can monitor this data in several different modes:

- Continuously.
- From a defined trigger point.
- Selective data captures.

The mode depends on the operational setup. It stores all the bus traffic, error and timing data. The Bus Monitor interfaces with the 68000 CPU. The Bus Monitor allows fully comprehensive message and error detection including multiple simultaneous errors.

Bus Monitor Signal Processor

The Bus Monitor signal processor is a TMS320E15 with 4K words of EPROM on a chip containing the bus monitor program. While it is running it accesses the 64K of static RAM to store the activity on the 1553 bus. It controls the signals and data flow coming from the 1553 bus. It can monitor and save this data on to the monitor stack for later reference.

1553 Receive Logic and Error Detection

The receive logic and error detection is based around a micro-sequencer. It decodes incoming 1553 bus words and detects errors. The receive logic is shared for the Bus Controller, Remote Terminals and Bus Monitor but each signal processor receives its own copy of data and errors. This allows independent operation of Bus Controller, Remote Terminals and Bus Monitor while minimising the amount of hardware required.

Static Ram

The static read only memory (SRAM) is dual ported, as it can be accessed by either the 68000 CPU or the onboard signal processor, TMS320E15.

3.4 MATE CIIL LANGUAGE CAPABILITY

Suretest 2704 supports the MATE language, with the MATE language being defined in **Appendix F** of this manual

3.5 ALTERNATE LANGUAGE CAPABILITY

To use the NATIVE language of the Suretest 2704 the user must issue the MATE command **GAL**. To return to MATE, simply issue the NATIVE language command **QM**.

The remaining paragraphs of this manual, with the exception of Appendix F, relate to the NATIVE language capabilities of Suretest 2704.

3.6 USING THE BUS CONTROLLER

3.6.1 Introduction

Up to 401 unique Bus Controller data blocks can be set up on SURETEST 2704 which are referred to as BC pages. Messages can be transmitted on either the primary bus, secondary bus or on both buses simultaneously as an error condition. The output voltage is programmable between 0 and 20 volts in 1 volt increments, the inter-message gaps for each BC page can be individually adjusted from 10us (8us in 1553A mode) to 30 seconds. The bus time-out can be set to any value in the range 14us (10us in 1553A mode) to 59999us. Multiple word errors can be generated on any of the command and data words for:

- Incorrect sync.
- Manchester coding.
- Word length (long or short).
- Parity.

Message errors can be generated for:

- Too many words.
- Too few words.
- Transmission on both buses.

3.6.2 Word Count Selection

On a normal transmission, the number of data words transmitted can vary from 1 to 32. To enable word count errors to be transmitted, SURETEST 2704 allows the number of transmitted data words to be set in the range 00 to 21 (hexadecimal). If the command to be sent is a transmit command, then the number of data words transmitted should be set to 00 for a good message because no data words are required. If the command to be sent is a receive command, then the number of words transmitted should be set equal to the word count field in the command word for a good message. If the command is for an RT--RT transmission then the number of data words transmitted must be set to 01.

3.6.3 Secondary Command (RT-RT)

For an RT-RT transfer, a message containing two contiguous command words is sent. The secondary command is actually sent as a data word with a sync error because the command word sync is the inverse of a data word sync. To make the first data word look like a command word, a sync error must be inserted. The final stage of setting the secondary command is to set the number of data words transmitted to 01 (see previous section on transmission data words). Secondary command errors can be entered in identical format (except sync error, which is reversed) to the primary command errors.

3.6.4 Data Word Entry

The data for transmission on each BC page consists of 33 data words numbered from 01 to 21 (hexadecimal). Each data word can be set to any value in the range 0000 to FFFF (hexadecimal). Alternatively, any data words can be set to one of the data functions available. A pseudo random data function and three sawtooth data functions are available and are covered in more detail in paragraph 3-7.

3.6.5 Data Word Errors

The possible word type errors are Py, Mn, Sy, Lg and Sh. These can be transmitted with each word.

3.6.6 Trigger Pulse Out

One special facility provided on each BC page is a trigger pulse which envelopes the BC page transmission. (Models 2701/2 only). On model 2703, a facility for external trigger of BC link page is provided.

3.6.7 Superseding Command

The second special facility provided is a superseding command following any of the 320 BC page transmissions. This facility is described in detail in paragraph 3-7.2 on advanced features.

3.6.8 Bus Controller Link Page

The link page is provided to allow selection of individual messages in an ordered sequence to define a single transmission. The default is for 320 message pages and a link page of 320 entries. A blank location will indicate the end of the frame. A BC page can be entered more than once on the link page so that patterns of transmission can be set up. Any break in the link terminates the sequence. It is possible to divide the link page into sections, each of which is then treated as a minor frame. The user specifies maximum messages per minor frame and number of minor frame. The minor frames are transmitted in sequence. The length of time per minor frame may be fixed. See paragraph 3-23 for details of free/fixed frame modes of operation, and paragraph 3-24 for configuration of link page entries and message pages.

3.6.9 Transmit

SURETEST 2704 can be set to transmit the entire contents of the link page either a defined number of repetitions from 00001 to 59999 or to transmit continuously.

3.7 USING THE MULTI-REMOTE TERMINALS

3.7.1 RT Page/Sub Page Description

The Multi-Remote Terminal function of SURETEST 2704 has 96KBytes of memory, which is divided up equally between the RT's. The memory is divided up into two kinds of blocks called master pages and sub pages. Each RT has one master page and 20 sub pages. Refer to figure 3-2.

The master page contains a description of the data that can be transmitted when that RT is commanded to do so (a transmit data block of 33 data words plus associated errors). The master page also contains all the generic information for a particular RT.

Each of the sub pages contains a transmit data block that can be allocated to any of the RT sub-addresses. There are 30 sub-addresses per RT (31 in 1553A) and 20 sub pages. The 20 sub pages can be allocated by the user to any 20 of the 30 sub-addresses (31 in 1553A) giving a unique transmit data block to any 20 of the sub-addresses. If a sub-address that has not been allocated a sub page is commanded to transmit, then it can take its data from the transmit data block in the master page. Any sub-address can be allocated a maximum of one sub page at a time.

Both the master pages and sub pages can be separately enabled or disabled. Any RT master page not enabled will cause a no response to be returned when that RT is addressed by a command. Any RT sub-address not enabled will transmit the data in the master page transmit data block, provided that the master page is enabled.

Additionally, the transmit data block within a master page can itself be enabled or disabled. If enabled, the operation will be normal. If disabled, the RT will receive but will not transmit data (it will become a receiver only).

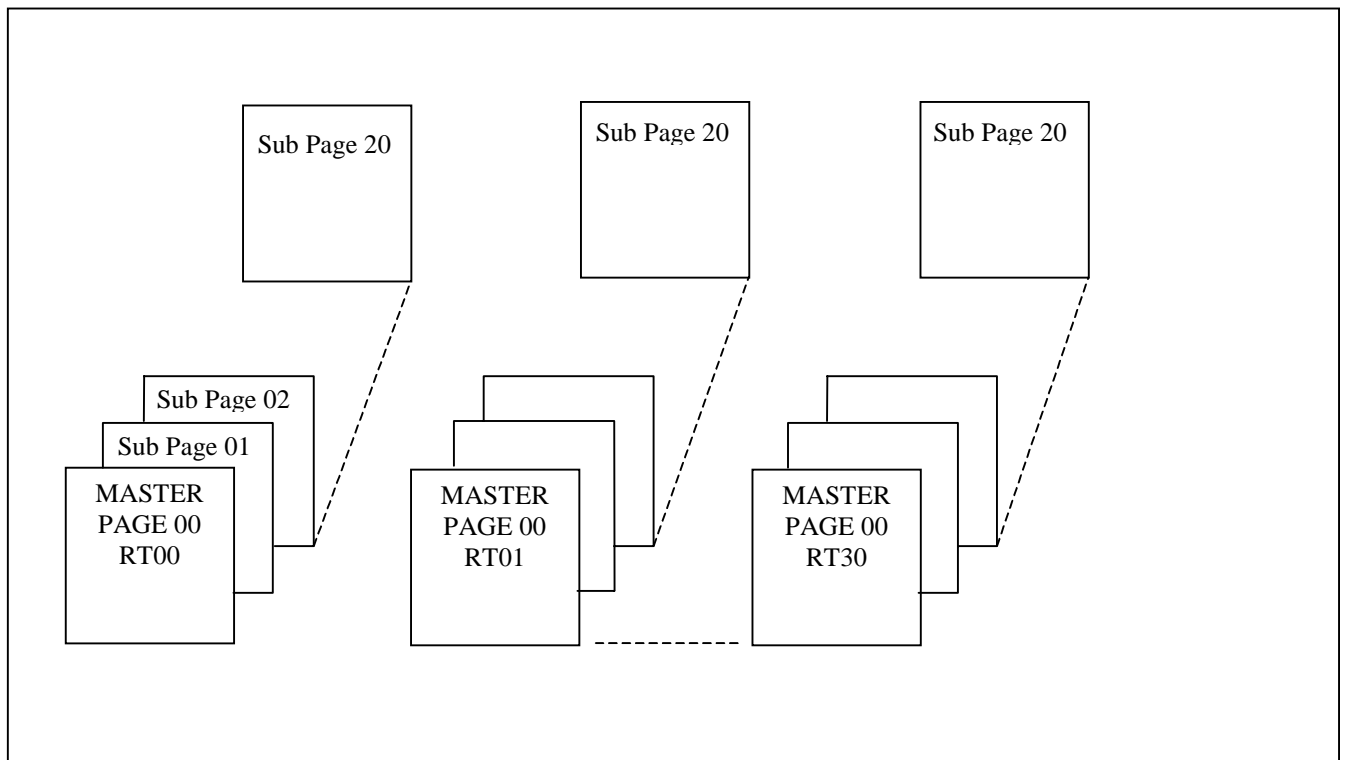

Figure 3-2 RT Structure

3.7.2 The Master Page

Response Time

The response time is programmable between 4 and 99us (2 and 97us in 1553A mode) in 1us increments.

Amplitude

The response amplitude is programmable between 0 and 20 volts in 1 volt increments. The amplitude is global, therefore all Remote Terminals will assume the last set amplitude.

Status Response

Each Remote Terminal can return a unique status response that is defined on the Master Page.

Status Word Errors

Each status word can be sent with a combination of errors.

Message Errors

Each Remote Terminal can return unique message errors of one too many words or one too few words, transmission on the wrong bus or transmission simultaneously on both buses.

Data Word Entry

The data for transmission on each RT page consists of 33 data words numbered from 01 to 21 (hexadecimal). Each data word can be set to any value in the range 0000 to FFFF (hexadecimal). Alternatively, any data words can be set to one of the data functions available. A pseudo random data function and three sawtooth data functions are available and are covered in more detail in paragraph 3-7.

Enabling the Master Page

The master page must be enabled if a Remote Terminal is to respond either from the master page or from any of the sub pages. The master page data can be disabled so that for any of the sub-addresses that have not been enabled, the RT SA combination will not respond.

Mode Code Response

Each Remote Terminal can respond to all 32 possible combinations of mode code. The default state is the MIL-STD-1553B values (MIL-STD-1553A in 1553A mode) (see Appendices A, B and C) but they can all be reassigned one of the following response types:

D	Dynamic bus control acceptance.
J	Respond with just status.
W	Respond with status and one data word.
T	Transmit last command.
R	Reserved (for example, no response).

3.7.3 Sub Pages

For each Remote Terminal, there are twenty sub pages which can be allocated to any twenty of the thirty available sub-addresses to provide a unique 33 word data block. Any sub-address required to transmit data which has no unique data block allocated, will transmit data from the master page for that particular Remote Terminal, if the master page data is enabled. Only one sub page can be assigned to any one sub-address for each Remote Terminal.

Sub-Address Sub Page

After power-up or reset, the first twenty sub-addresses are allocated to the first twenty sub pages respectively. These may be reallocated.

Enabling a Sub Page

To allow data to be transmitted from a page, the sub page must be enabled as well as the master page for the particular Remote Terminal in question.

Data Word Entry

Data word entry for the Remote Terminal sub pages is identical in format to the data word entry for the master pages described in paragraph 3.4.4.

3.8 USING THE BUS MONITOR

3.8.1 Introduction

The Bus Monitor is capable of monitoring all bus activity on both the primary and secondary buses. Information can be captured and displayed with a combined pre-trigger and post-trigger count of 10920 words. The Bus Monitor can be armed by external hardware trigger and/or by certain commands appearing on the bus. The Bus Monitor can be enabled to capture all data on the bus (example, no trigger) or can be set up to trigger on specific word type, word content and/or errors. The word type trigger is available either for command word, data word, status word, status message error bits or the second command of an RT-RT transfer. Word content trigger is available to express the 16-bit word trigger with don't-care states as required.

Error trigger is available from:

- Terminal address error.
- Manchester code error.
- Parity error.
- Transmission on the wrong bus.
- Transmission, both buses simultaneously.
- No response
- Word count error
- Long word.
- Short word.
- Slow response

If multiple errors are specified for the trigger condition then the Bus Monitor will trigger on any of the selected errors. In order that the Bus Monitor may record no response and slow response errors, a time-out value has to be set identical to the bus time-out of the Bus Controller. The time-out can be set in 1us steps between 14 (10us in 1553A mode) and 59999us. In addition to normal trigger capture, where all bus traffic is recorded after the defined trigger condition has been met, the Bus Monitor can be set for selective capture where only data associated with given command(s) is recorded. The Bus Monitor can be used in **snap mode** to provide a constantly updated display of bus activity.

3.8.2 Trigger Condition

In the **WINDOW** mode, once the trigger is armed the trigger condition is required to be satisfied within that message.

In the **CONTINUOUS** mode, once the trigger is armed the monitor will wait indefinitely for the trigger condition to be satisfied.

Data Number

This allows the user to trigger on a particular data word number.

Trigger Word Bit Pattern

This allows the user to trigger on a specific word value.

Post Trigger Count

This sets the number of words to be captured after the trigger condition has been met.

Trigger Errors

TA	Terminal Address	WC	Word Count
NR	No Response	Mn	Manchester
SR	Slow Response	Lg	Long Word
BB	Both Buses	Sh	Short Word
WB	Wrong Bus	Py	Parity

No Response Time-Out

This value should be identical to the bus time-out for the Bus Controller being used (internal or external).

Capture Mode

Normal: Captures everything.
Selective: Captures only selected messages.

3.8.3 64KByte DRAM Buffer Operation

A24 Access

This 64KByte of DRAM is always available to be read through A24. After a capture, the information between and including **TRIG** and **EOTD** (End of Trigger Data) will be automatically sent from the SRAM to the A24 DRAM. Bits zero of the Status byte will be set when the transfer is complete. It is set up, so that the user can decide on the validity of the data, for example, where it ends. This can be calculated for instance from the response to an **E** command (transmit EOTD).

Word Serial Protocol (WSP) Access

The transmit bus monitor stack command will take a number of words from the SRAM (whether they are between TRIG and EOTD does not matter) and make them available to be read from a VXI buffer by means of the WSP read mechanism.

Example: T+0000100005

This makes five bus word descriptions available from the SRAM (five bus words means 15 memory words). The first word will be the TRIG word.

In order to avoid confusion with data that will be captured in the future, all of this data should be read or cleared from the buffer before reading the new data.

Example:

B001C01NAAAA

LBO

LM

T+000100004 Put four words in buffer

ibrd 45 03F6 0821 0000 Read three words and leave one behind in buffer
0000 AAAA 4800
03F7 0821 0100

NOTE

ibrd is specific to a certain software package and any equivalent command/software package which accomplishes the same read will suffice.

B001C01NBBBB

LM

T+0000100004 Put four words in buffer

ibrd 75 0000 AAAA 4800 Try reading five but get only one

ibrd 75 03F6 0821 0000 Try reading five but only four exist in buffer.
0000 BBBB 4800
03F7 0821 0100
0000 BBBB 4800

3.9 SAWTOOTH / RANDOM FUNCTION

3.9.1 Introduction

SURETEST 2704 provides eight data algorithms that enable constantly changing data words to be transmitted. Three sawtooth algorithms and one pseudo random algorithm can be individually specified for each of the Bus Controller and Remote Terminal. Each sawtooth function is provided with an initial value (lower limit), an upper limit and an increment parameter. When the Bus Controller starts transmitting, all three sawtooth functions are set to their respective initial values. Each time a sawtooth function is requested for transmission, the current data value is transmitted and the respective step value is added to the data value afterwards until the current data value equal to upper limit then the current data value is set to the lower limit. As each data word is modulo sixteen, when the step value is added to the previous data value and the sum is greater than FFFF (hexadecimal), the value is wrapped around through 0000. This allows for a negative ramp and is achieved as follows:

```

Lower Limit = 00D0
Upper Limit = FFF6
Step Value = FFFC
Therefore 1st value is      00D0

2nd value is                00D0
                           +FFFC

Disregard (modulo 16)      1 00CC      2nd value is 00CC
A ramp of -4 is produced from a step value of FFFC
    
```

3.9.2 Superseding Command

A facility is provided to enable a superseding command to be issued either on the primary bus or on the secondary bus. The superseding command is intended to be used in conjunction with external Remote Terminals. The superseding command can be programmed to occur from **2us** to **30000us** in 0.5us stages after the start of a message from any of the 320 BC pages. Only one superseding command is available although it can be called from numerous BC pages. Refer to figure 3-3.

NOTE: *When using superseding commands the internal RT's are inaccessible.*

The remaining setup is identical to setting up a normal BC page covered in paragraph 3.4, except that no bus time-out can be set.

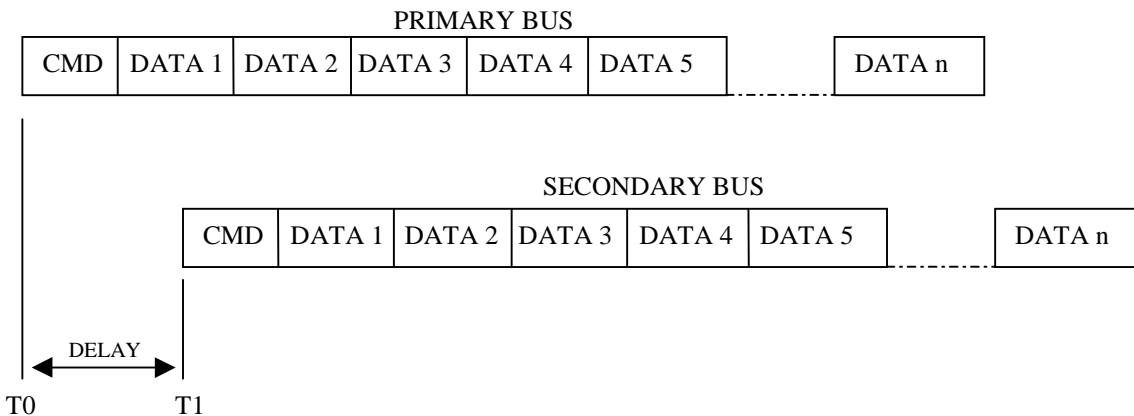

Figure 3-3 Superseding Command Timing

3.10 DRAM OPERATION

There is 1 Mbyte of DRAM on the SURETEST 2704 board, 256KBytes of that is available to the user. This is called the user DRAM and has a Base Address of \$20000. This memory is mapped to the 68000 microprocessor and can be used to store executable programs written as subroutines (example, terminated by a RTS (Return from Subroutine)) in 68000 code. The code can be loaded into the DRAM by means of the command **U** followed by the code in S-Record (S2) format and terminated by an S8 record.

The program can be executed by sending the command string **JR** followed by the DRAM address \$20000.

The microprocessor performs a variety of functions, for example;

- ≡ Parsing and execution of the Word Serial Commands.
- ≡ Moving of the stack to the 64KBytes of DRAM for downloading through A24 access.
- ≡ Writing to the registers used by the real-time microprocessors etc.

All of these functions can either be enhanced or over ridden by executing the user DRAM programs together with or instead of the programs resident in the 68000 PROMS for normal operation.

Examples:

1. Add another parser and execute software so that another set of ASCII commands could be made available for some customer specific requirements.
2. Execute part or the entire applications program from DRAM, for time critical applications.
3. Check the monitored information continually and extract important information for the user. This could be a customer specific snap view for example.

All of these applications will require a fairly high level of expertise and the basic requirements for successful use are as follows;

1. Some means of creating 68000 code.
2. Some means of generating S-Records.
3. A thorough understanding of what hardware the 68000 microprocessor controls on the board.
4. A complete and accurate memory map of the board, both from the 68000 and the TMS320E15 points of view.

SECTION II. OPERATING INSTRUCTIONS

3.11 INTRODUCTION

Each of the commands for SURETEST 2704 start with one of the function characters defined in table 3-1. The general format of the commands are data strings consisting of command characters and/or numbers. Some data strings require only a single command character, whereas others may require a sequence of command characters and numbers. Each command character or number is described as a field in the data string. In the following data string descriptions, the fields enclosed in the < and > symbols represent numbers. An example will be provided of usage where applicable. For the Bus Controller, Remote Terminals and Bus Monitor, the individual command statements can be concatenated within each command string to avoid repeating the command character at the start of each string. Commas or white space may be used to delimit fields. Delimiter must be used where ambiguity would exist without them. Refer to figure 3-4 Top Level Syntax Diagram. Full language syntax diagrams are contained in figures 3-4 through 3-11 and figure 3-13.

3.12 SET UP BUS CONTROLLER

To set up the Bus Controller the first character of the command string is B, followed by one to three decimal characters to define the number of BC message pages to be set up. Valid range is 1 to 320. Should more than 320 BC message pages be required, this may be increased to a maximum value of 401, using the **CBM** configuration change command prior to defining a BC page in excess of the default limit. (See paragraph 3-24 for configuration command details). To program multiple functions for the same BC page number, a new function character (with associated characters, where applicable) must be added. There is no limit on the number of different functions that can be added to a BC message page in a single command string, provided that the string does not exceed 256 bytes, and appropriate delimiters are used, if required by function syntax. Function characters and descriptions applicable to any BC message are listed below. Refer to figure 3-5 Bus Controller Setup Syntax Diagram

Character	Command Description
A	Change Transmission Amplitude
B	Change Transmission Bus
C	Change Data Word Contents
E	Change Data Word Errors
F	Change Sawtooth Data Function
G	Enable Trigger Pulse
H	Disable Trigger Pulse
I	Change Inter-Message Gap
K	Disable Superseding Command
L	Change Link Page Entry
N	Change Transmission Data Word Count
R	RT Data Query Command
S	Enable Superseding Command
T	Change Bus Time-out
W	Wait Command

Change Transmission Amplitude

A<nn> <nn> = One or two decimal characters in the range **0** to **20** for the transmission amplitude.

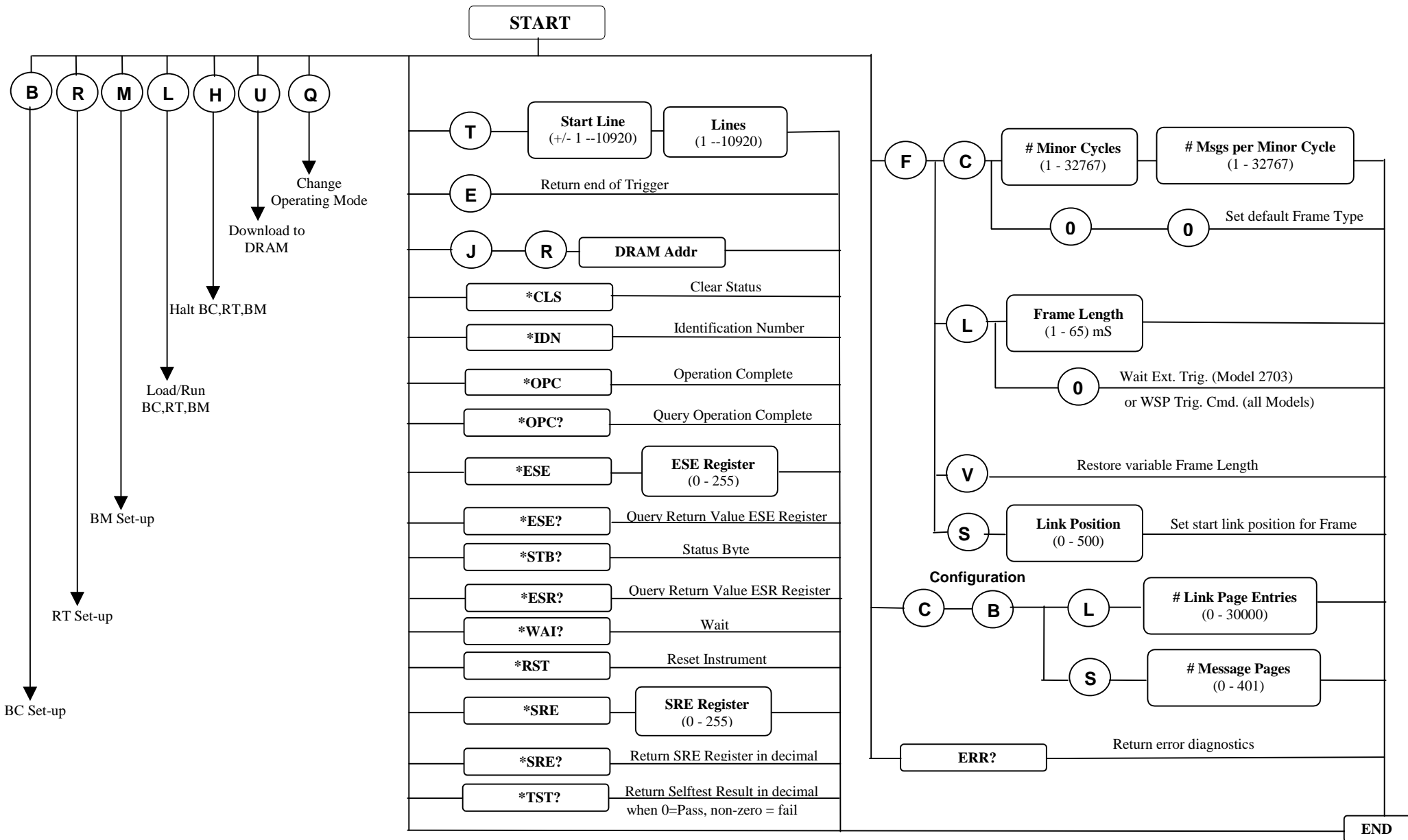

Figure 3-4 Top Level Syntax Diagram

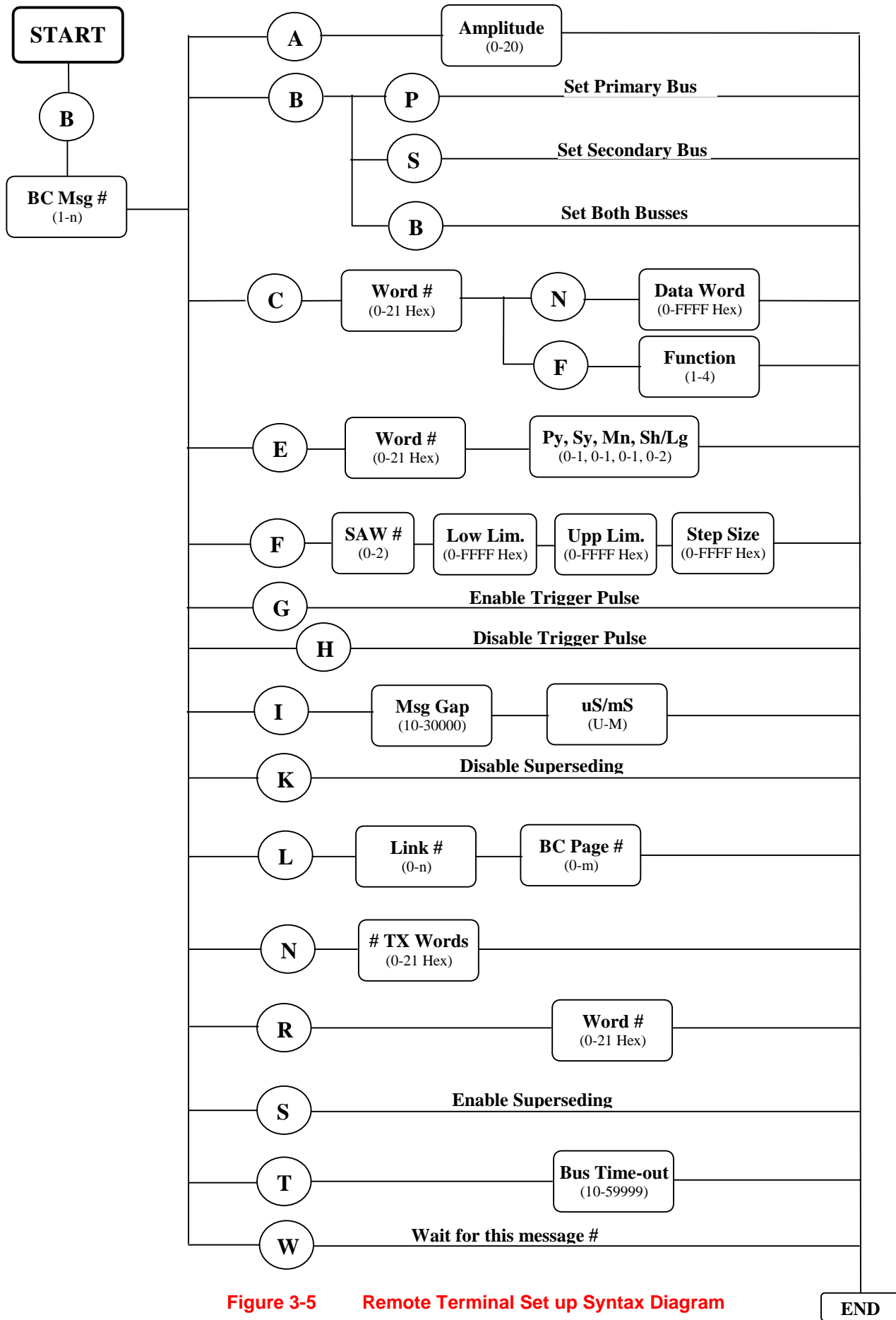

Figure 3-5 Remote Terminal Set up Syntax Diagram

Change Transmission Bus

Bc **c** = One character representing the transmission bus, either **P** for primary bus, **S** for secondary bus or **B** for both buses.

Change Data Word Content

C<dd>**c**<nxxx> <dd> = One or two hexadecimal characters in the range **0** to **21** specifying the word to be changed where **0** represents the command word and **1** to **al** represents data words.

c = One character to indicate the type of data word where **N** represents a normal data word and **F** represents a data function.

 <nxxx> = If word type **N** has been selected, one to four hexadecimal characters in the range **0** to **FFFF** for the data word value. If word type **F** has been selected, add in one hexadecimal character in the range **0** to **3** defining the function required. **0=SAWI, 1=SAW2, 2=SAW3** and **3=RAND**. This completes the command sequence for setting a command or data word.

Change Data Word Errors

E<dd>**psmc** <dd> = One or two hexadecimal characters in the range **0** to **21** to define the word number where **0** represents the command word and **1** to **21** represents data words.

p = **0** to disable or **1** to enable a parity error.

s = **0** to disable or **1** to enable a sync error.

m = **0** to disable or **1** to enable a Manchester error.

c = **0** to disable word count error, **1** to enable short word error or **2** to enable long word error.

An entry must be made for **p, s, m, c**, with comma delimiters.

Change Sawtooth Data Function

Fn<lll><uuuu><ssss>

n = A single decimal character in the range **0** to **2** to define the sawtooth number to be changed where **0** represents sawtooth 1, **1** represents sawtooth 2, and **2** represents sawtooth 3.

 <lll> = One to four hexadecimal characters in the range **0** to **FFFF** defining the lower limit (initial value) of the data function.

 <uuuu> = One to four hexadecimal characters in the range **0** to **FFFF** defining the upper limit of the data function.

 <ssss> = One to four hexadecimal characters in the range **0** to **FFFF** defining the increment of the data function.

See paragraph 3.12 for details of setting negative ramp values.

Should less than four characters be used in **l, u,** and **s** fields, then commas are needed as delimiters.

Enable Trigger Pulse

To enable the trigger pulse use the **G** option that requires no further characters.

Disable Trigger Pulse

To disable the trigger pulse, use the **H** option that requires no further characters.

Change Inter-Message Gap

I<nnnnn>c <nnnnn> = One to five decimal characters in the range 00000 to 30000 defining the inter-message gap value.

 c = One character for the units for the inter-message gap where **U** represents microseconds and **M** represents milliseconds (error if value <10us(8us in 1553A mode)).

Disable Superseding Command

To disable the superseding command, use the **K** option that requires no further characters.

Change Link Page Entry

L<nnnnn><mmm> <nnnnn> = One to five decimal characters defining location in link page. In default condition, up to 320 max. Up to 30000 permissible, after re-configuring.

 <mmm> = One to three decimal characters defining the BC page number. In default condition, up to 320 max. Up to 401 permissible, after configuring.

To alter default limits, refer to paragraph 3.24, configuration commands. These must be performed prior to using link page entries or BC message page entries outside 320 default upper limits.

Change Transmission Data Word Count

N<nn> <nn> = One or two hexadecimal characters in the range **0** to **21** defining the number of data words to be transmitted.

RT Data Query Command

R<nn> <nn> = One or two hexadecimal characters in the range **0** to **21** defining the RT response data word to be returned from this message.

RT response data word **0** returns the RT status word. If the most recent message had no response from the RT then the string **????** is returned instead of a hex number.

The time from sending the command via the VXI WSP and the response being available is not greater than 650us.

Enable Superseding Command

To enable the superseding command, use the **S** option that requires no further characters.

Change Bus Time Out

T<nnnnn> <nnnnn> = Two to five decimal characters in the range 14 (10 in 1553A mode) to 59999 for the required time-out value in **microseconds**.

Wait Command

To allow the user software to synchronise with a particular command on the 1553 bus use the **W** option that requires no further characters.

Waiting for a message, which is never transmitted, will cause the board to hang up. Only reset will clear this condition.

Example Using Bus Controller Commands:

To set up BC page six to transmit on the secondary bus with an amplitude of 19 volts and the second data word to have the value **1234**.

B6BS	(Transmit on secondary bus)
B6A19N	(Amplitude 19 volts)
B6C2N1234	(2nd data word = 1234)

The example above could be transmitted as one command string as follows:

B6BSA19C2N1234

3.13 SUPERSEDING COMMANDS

The superseding page is programmed by using zero for the BC page number. Only a subset of the commands available to the normal BC page is available, as shown below, for the superseding page. The following examples explain the syntax required for each function in the order that they appear in the table 3-2. Refer to figure 3-6 Superseding Commands Setup Syntax Diagram.

Character	Command description
A	Change Transmission Amplitude
B	Change Transmission Bus
C	Change Data Word Contents
E	Change Data Word Errors
K	Disable Superseding Page
N	Change Transmission Data Word Count
S	Enable Superseding Page
T	Change Superseding Delay Value

The options, **A**, **B**, **C**, **E** and **N** are identical to a normal BC page and are covered in the general section on the Bus Controller (see paragraph 3-10).

Disable Superseding Page

To disable the superseding page, use the **K** option that requires no further characters.

Enable Superseding Page

To enable the superseding page, use the **S** option that requires no further characters.

Change Superseding Delay Value

T<nnnnn> <nnnnn> = One to five decimal characters in the range **4** to **59999** to define the delay in multiples of 0.5 microseconds.

Change Transmission Bus

B<c> <c> = One character defining the transmission bus, either **P** for primary bus or **S** for secondary bus.

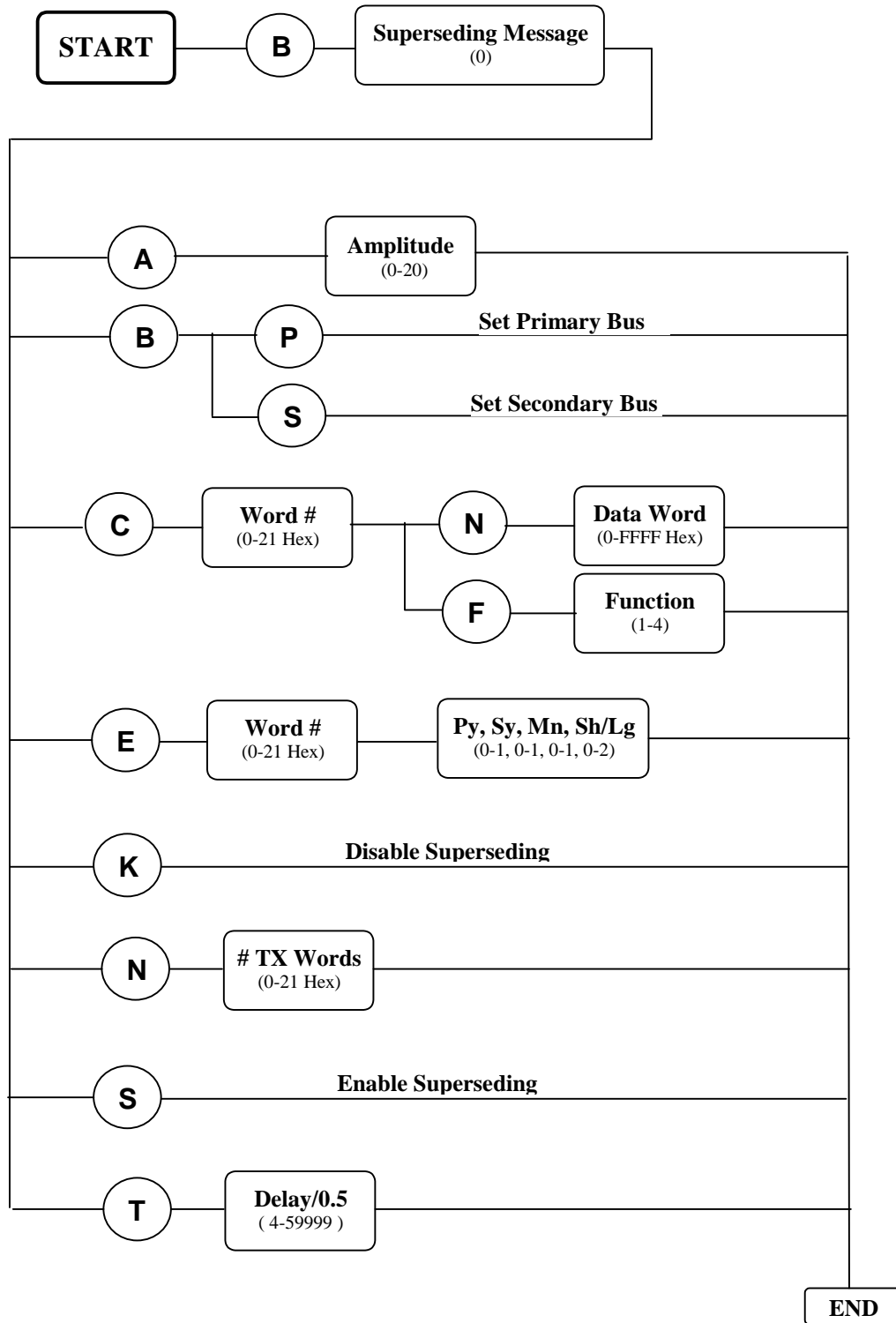

Figure 3-6 Superseding Command Set-up Syntax Diagram

3.14 SET UP REMOTE TERMINAL

A Remote Terminal is set up using the first character of the command string **R**. The string must be followed by one or two hexadecimal characters in the range **0** to **1E** (**1F** in 1553A mode) to specify the Remote Terminal number to be changed. The next field requires one or two decimal characters in the range **0** to **20**, defining the page number to be changed where **0** represents the master page and **1** to **20** represent the sub-pages. The remaining section of the command string is dependent on the function required. To program multiple functions for the same Remote Terminal page number, a new function character with associated characters must be added. There is no limit on the number of different functions programmed for a Remote Terminal page in a single command string providing that the string length does not exceed 256 bytes. The available function characters and their descriptions are listed below. The following examples explain the syntax required for each function in the order that they appear in the table. The options **D**, **G**, **H** and **I** require no further characters. Refer to figure 3-7 Remote Terminal Setup Syntax Diagram.

Character	Command Description
A	Change Response Amplitude
C	Change Data Word Value
D	Disable RT or Sub page
E	Change Data Word Errors
F	Change Sawtooth Data Function
G	Enable RT
H	Enable Master Page Data
I	Disable Master Page Data
M	Change Mode Code
S	Change Sub-Address and Enable
T	Change Response Time
X	Change Message Errors

Change Response Amplitude

A<nn> <nn> = One or two decimal characters in the range **0** to **20** for the response amplitude. This completes the command string for setting the response amplitude.

Change Data Word Value

C<dd><c><nnnn> <dd> = One or two hexadecimal characters in the range **0** to **21** defining the word to be changed where **0** specifies the status word and **1** and upwards specifies data words.

c = One character to indicate the type of data word where **N** represents a normal data word and **F** represents a data function.

<nnnn> = If the word type selected was **N** add one to four hexadecimal characters in the range **0** to **FFFF** for the data word value. If the word type selected was **F**, add one to four hexadecimal characters in the range **0** to **3** defining the function required. **0=SAW1**, **1=SAW2**, **2=SAW3** and **3=RAND**. This completes the command string for changing a status or data word.

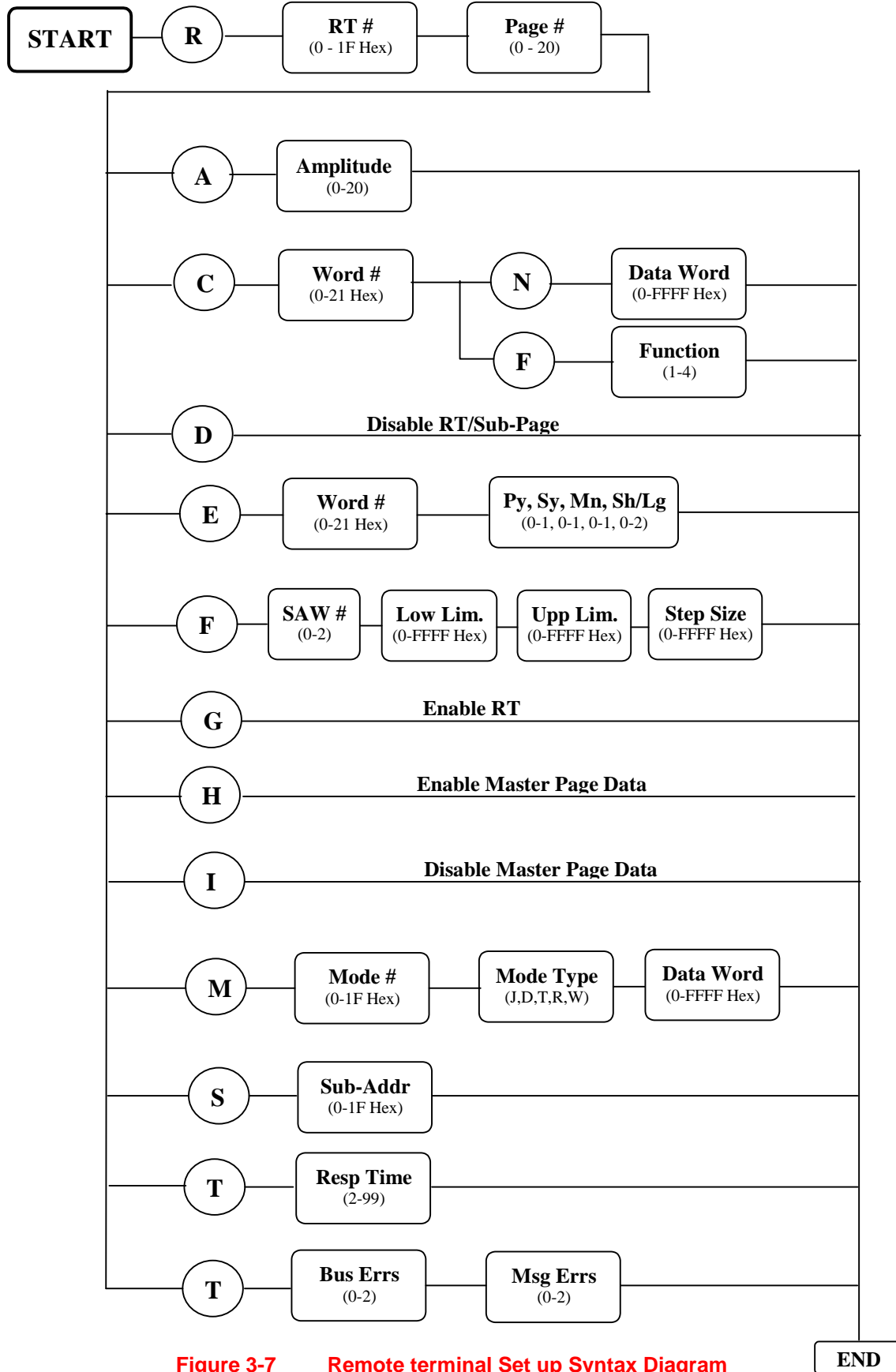

Figure 3-7 Remote terminal Set up Syntax Diagram

Change Data Word Errors

E<dd>psmc <dd> = One or two hexadecimal characters in the range **0** to **21** to define the word number where **0** represents the command word and **1** to **21** represents data words.

 p = **0** to disable or **1** to enable a parity error.

 s = **0** to disable or **1** to enable a sync error.

 m = **0** to disable or **1** to enable a Manchester error.

 c = **0** to disable word count error, **1** to enable short word error or **2** to enable long word error.

An entry must be made for **p**, **s**, **m**, **c**, with comma delimiters.

Change Sawtooth Data Function

Fn<llll><uuuu><ssss>

 n = A single decimal character in the range **0** to **2** to define the sawtooth number to be changed where **0** represents sawtooth 1, **1** represents sawtooth 2, and **2** represents sawtooth 3.

 <llll> = One to four hexadecimal characters in the range **0** to **FFFF** defining the lower limit (initial value) of the data function.

 <uuuu> = One to four hexadecimal characters in the range **0** to **FFFF** defining the upper limit of the data function.

 <ssss> = One to four hexadecimal characters in the range **0** to **FFFF** defining the increment of the data function.

See paragraph 3.12 for details of setting negative ramp values.

Should less than four characters be used in **l**, **u**, and **s** fields, then commas are needed as delimiters.

Change Mode Code

M<mm>c<nnnn>

<mm> = One or two hexadecimal characters in the range **0** to **1F** for the required mode code.

 c = One single character defining the response type either **D**, **J**, **R**, **T** or **W**.

<nnnn> = One to four hexadecimal characters in the range **0** to **FFFF** defining the associated data word. This completes the command string for changing a mode code response.

D- Dynamic Bus Control.
J- Reply with Just status.
T- Transmit last command.
R- Reserved (no response).
W- Reply with status and data word.

Change Sub-Address and Enable

S<nn> <nn> = One or two hexadecimal characters in the range **00 (01** in 1553A mode) to **1E** to represent the required sub-address to be changed and enabled. This completes the command string for setting and enabling a sub-address.

Change Response Time

T<nn> <nn> = One or two decimal characters in the range 4 to 99 (2 to 97 in 1553A mode) to represent the response time in microseconds. This completes the command string for setting the response time.

Change Message Errors

Xbc b = A decimal character in the range 0 to 2 to represent the bus errors, where 0 disables bus errors, 1 enables both buses error and 2 enables wrong bus error.

 c = A decimal character in the range 0 to 2 to represent the word count errors, where 0 disables word count errors, 1 enables one too few words error and 2 enables one too many words error. This completes the command string for setting message errors.

Example of Remote Terminal Operation:

To enable RT 03 sub address 1C on sub page 07 with the master page data disabled and mode code 01 set to transmit status and one data word of 4321.

R0307G	(Enable Master Page)	or R3,7G
R0307S1C	(Enable sub-address)	or R3,7S1C
R03071	(Disable Master Page data)	or R3,71
R0307M01D4321	(Set mode code response)	or R3,7M1,D4321

The above example could be expressed as one command string as follows:

R0307GS1C1M01D4321 or R3,7GS1C1M1,D4321

3.15 SET UP BUS MONITOR

The Bus Monitor is set up using the first characters of the command string **M**. The remainder of the command string is dependent on the function required. To program multiple functions for Bus Monitor, a new function character with associated characters must be added. There is no limit on the number of different functions programmed in a single command string providing that the string does not exceed 256 bytes. The available; function characters and their descriptions are listed below. Refer to figure 3-8 Bus Monitor Setup Syntax Diagram.

Character	Command Description
A	Enable External Hardware Arming of Trigger
B	Disable External Hardware Arming of Trigger
C	Change Post-Trigger Count Value
E	Change Error Trigger Condition
G	Enable Trigger on Error
I	Disable Trigger on Error
K	Enable Software Arming of the Trigger
L	Disable Software Arming of the Trigger
M	Change Capture Mode
N	Change Data Number
P	Change Trigger Word Bit Pattern
Q	Enable Window Mode
R	Enable Continuous Mode
T	Change Bus Time-out Value
U	Change the Arming Command Bit Pattern
V	Change the Selective Command Bit Pattern
W	Change Word Type Trigger Condition
Z	Monitor Mode Command

The options **A, B, G, I, K, L, Q, R**, require no further characters.

Change Post-Trigger Count Value

C<nnnnn> <nnnnn> = One to five decimal characters in the range **1** to **1092** defining the post-trigger count in bus words. This completes the command string for setting the post-trigger count.

Change Errors for Trigger

E<nnnn> <nnnn>= One to four hexadecimal characters in the range **0** to **03FF** to represent the error condition as defined below. Each of the ten least significant bits in the trigger error word represents a particular error type, as shown below.

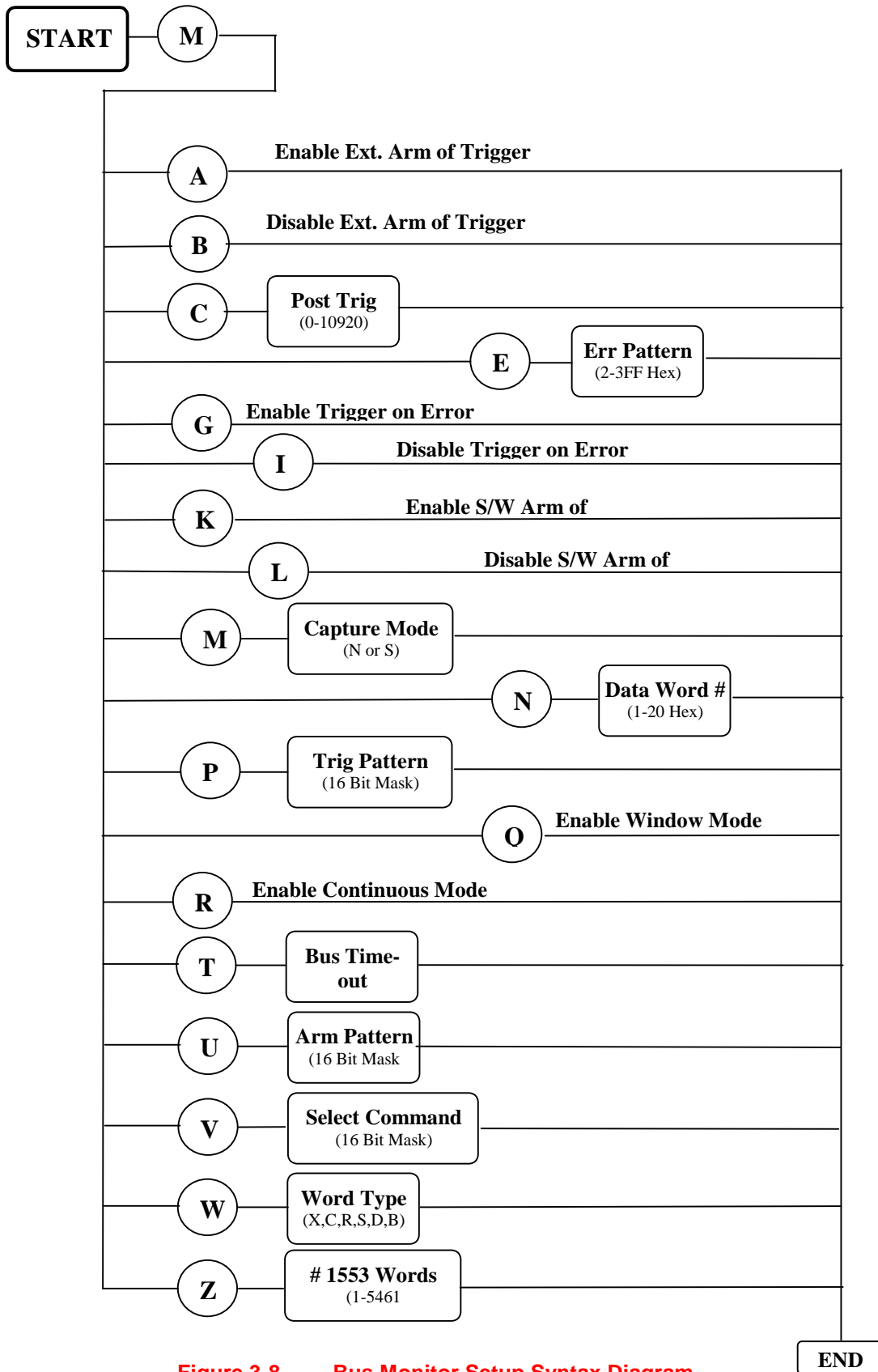

Figure 3-8 Bus Monitor Setup Syntax Diagram

Error Trigger Bits

Bit	Error Type
0	Parity
1	Short Word
2	Long Word
3	Manchester
4	Word Count (too few or too many)
5	Wrong Bus
6	Both Busses
7	Slow Response (response > Bus time-out)
8	No Response
9	Terminal Address
10	Not Used
11	Not Used
12	Not Used
13	Not Used
14	Not Used
15	Not Used

Example: To enable the trigger on a terminal address error, wrong bus error and a parity error, the bit pattern required would be 0000001000100001 which is 0221 hexadecimal.

This completes the command string for setting the error trigger.

Change Capture Mode

Mc **c =** One character to define the capture mode, either **N** for normal capture or **S** for selective capture. This completes the command string for setting the capture mode.

Change Data Word Number

N<nn> **<nn> =** One or two hexadecimal characters in the range **1** to **20** defining the data number for that trigger condition.

Change Trigger Word Bit Pattern

P<nnnnnnnnnnnnnnnn> Each of the 16 n's define the individual bits of the trigger word. To enable the trigger when a particular bit is logic 1 is set to 1. To enable the trigger when a particular bit logic 0, **n** is set to 0 and to exclude a particular bit from the trigger condition **n** is set to 1. This completes the command string for setting the trigger word contents.

Change Bus Time-Out Value

T<nnnnn> <nnnnn> = Two to five decimal characters in the range **14** (**10** in 1553A mode) to **59999** defining the bus time-out in microseconds. This completes the command string for setting the bus time-out.

Change the Arming Command Bit Pattern

U<nnnnnnnnnnnnnnnn> Each of the 16 n's define the individual bits of the arming command and are set to **1**, **0** or **X** (don't care) as required.

Change the Select Command Bit Pattern

V<nnnnnnnnnnnnnnnn> Each of the 16 n's define the individual bits of the select command and are set to **1**, **0** or **X** (don't care) as required.

Change Word Type Trigger Condition

Wn n = One character defining the type of word to trigger on where:

- X** Any of the below
- C** Command word
- R** RT-RT transfer
- S** Status
- D** Data
- B** Status message error bits

Monitor Mode Command

Z<nnnn> <nnnn> = One to four decimal characters in the range 0 to 5461 defining the size of the buffer in 1553 words.

- <nnnn> = 0 Sets the BM into Trigger Mode.
- <nnnn> = 1 Chooses a buffer size of 32KBytes.
- <nnnn> = 2 to 5461 Chooses a buffer size of (nnnn * 6) bytes.

Now when the board receives the **LM** command it fills the buffers cyclically. It reports in the VXI registers at offset 20H, the address offset from the base (in bytes) of the most recently filled buffer. At initialization, this register is set to FFFF.

The anticipated 1553 traffic within a particular buffer must have a total dead time of 60 uS.

NOTE

If the user specifies a buffer size which consists of a single message of two 1553 words this would impose a minimum IMG of 60 uS. If the buffer consists of more than one message then the imposed IMG is reduced in proportion to the number of messages.

3.16 LOAD AND RUN BC, RT or BM

To load the prepared test sequence and run the Bus Controller, Remote Terminals or the Bus Monitor, use the first characters of the data string **L**,

The remaining section of the command string is dependent on the function required. The available function characters and their descriptions are listed below. The command characters **M** and **R** require no further characters. Refer to figure 3-9 Load/Run BC, RT, BM Syntax Diagram.

Character	Command Description
B	Load and Run the Bus Controller
M	Load and Run the Bus Monitor
R	Load and Run the Remote Terminals

B<nnnnn> <nnnnn> = One to five decimal digits in the range 0 to 59999 defining the transmit loop count. When the loop count is 0, the BC will transmit forever.

SURETEST 2704 can be set to transmit the entire contents of the link page for a defined number of times from 1 to 59999 or to transmit continuously.

When the Bus Monitor has completed the current capture, a request true event will be issued and SURETEST 2704 will respond with the status word set to 41H.

When the Bus Controller has completed the current transmission, a request true event will be issued and SURETEST 2704 will respond with the status word set to 41H.

The Bus Monitor stack will be updated for unloading only when the Bus Monitor is halted or the capture is complete.

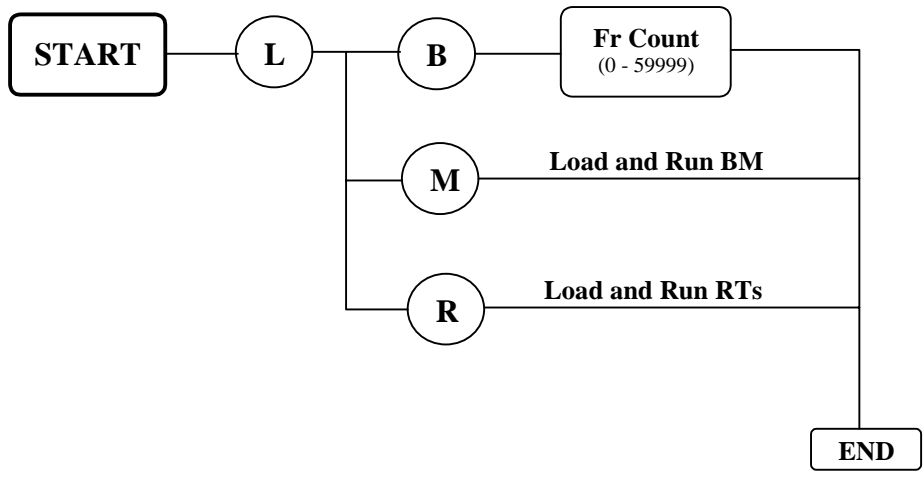

Figure 3-9 Load/Run BC, RT, BM Syntax Diagram

3.17 HALT BC, RT or BM

To halt the Bus Controller, Remote Terminals or Bus Monitor, use the first characters of the string **H**, followed by a single character for the facility to be halted. The remaining section of the command string is dependent on the function required. The available function characters and their descriptions are listed below. Refer to figure 3-10 Halt BC, RT, or BM Syntax Diagram. The command string can not be concatenated.

Character	Command Description
B	Halt the Bus Controller
M	Halt the Bus Monitor
R	Halt Remote Terminals

NOTE

If the Bus Monitor is still capturing data then Halt Monitor **must** be sent before retrieving stack information.

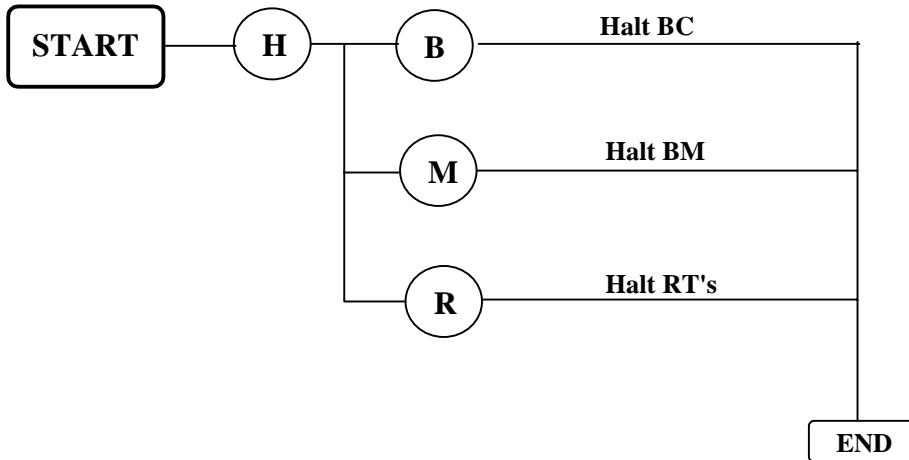

Figure 3-10 Halt BC, RT, BM Syntax Diagram

3.18 TRANSMIT BUS MONITOR STACK

The Bus Monitor stack is returned as a series of hexadecimal bytes, by using the command string in the format:

Tc<aaaaa><bbbbbb>

- c = + to transmit post-trigger data or
- to transmit pre-trigger data.
- <aaaaa> = One to five decimal characters in the range **1** to **10920** defining the line number for the start of transmission, where **1** represents the line number of the trigger point.
- <bbbbbb> = Five decimal characters in the range **1** to **10920** defining the number of bus words to be transmitted.

Data returned is in lines of 14 hexadecimal bytes, terminated by commas.

Each line represents three words of four hexadecimal characters, separated by spaces.

Example:

When the BC is set up to transmit a free frame of three messages, using command strings:

"B001C01N1111"	/Set Bus Message page 1, change data word 1 to normal data word, 1111 hexadecimal
"B002C01N2222"	/Set Bus message page 2, change data word 1 to normal data word, 2222 hexadecimal
"B003C01N3333"	/Set Bus message page 3, change data word 1 to normal data word, 3333 hexadecimal
"BIL0,I,L1,2,L2,3"	/Setup the link page, to message sequence message 1, message 2, message 3
"LM"	/Load and run Monitor
"LBO"	/Transmit forever
"T+000010006"	/Transmit post-trigger data, from trigger point, six bus words

Data returned as:

FF02 0821 0000	/FF02 = Timing bus word 1, 0821 data bus word 1, 0000 errors bus word 1
0000 1111 4800	/0000 = Timing bus word 2, 1111 data bus word 2, 4800 errors bus word 2
03F5 0821 0100	/03F5 = Timing bus word 3, 0821 data bus word 3, 0100 errors bus word 2
0000 2222 4800	/0000 = Timing bus word 4, 2222 data bus word 4, 4800 errors bus word 4
03F5 0821 0100	/03F5 = Timing bus word 5, 0821 data bus word 5, 0100 errors bus word 5
0000 3333 4800	/0000 = Timing bus word 6, 3333 data bus word 6, 4800 errors bus word 6

The first word (FF02) is the time in microseconds, from the preceding bus word to the current bus word. The second word (0821) is the bit pattern (16 bits) of the bus word, in this case CMD 01 R 01 01. The third word (0000) gives the word type and any errors related to that bus word, the individual bits of the word are defined as follows:

Bit 0		Parity error	
Bit 1		Too few bits (short word)	
Bit 2		Too many bits (long word)	
Bit 3		Manchester encoding error	
Bit 4		Word count error (too many or too few words)	
Bit 5		Wrong bus error	
Bit 6		Both buses error	
Bit 7		Slow response (response > Bus time-out)	
Bit 8		No response error	
Bit 9		Terminal address error	
Bit 11			
Bit 12	<u>Bit 12</u>	<u>Bit 11</u>	
	0	0	Command word
	0	1	Data word
	1	0	Status word
	1	1	RT-RT transfer
Bit 13	>	0	Data received on primary bus
	>	1	Data received on secondary bus
Bit 14	>	0	Sync type was command sync
	>	1	Sync type was data type
Bit 15			Not used

3.19 TRANSMIT MONITOR EOTD

To download the bus monitor EOTD (end of trigger data) line number, transmit the VXI word serial protocol language command string **E**. Refer to figure 3-4 Top Level Syntax Diagram.

The data returned will be a five byte ASCII decimal string representing the stack line number corresponding to the EOTD position.

3.20 DOWNLOAD DATA TO DRAM

To enable 68000 code to be loaded into DRAM on the CPU board and then executed the user is provided with 256Kbytes of user DRAM memory. The base address of the DRAM is \$20000. User programs can be downloaded to the DRAM by the command **U** followed by S-Records (S2). The download is terminated by an S8 record. Download to DRAM Syntax Diagram is shown below.

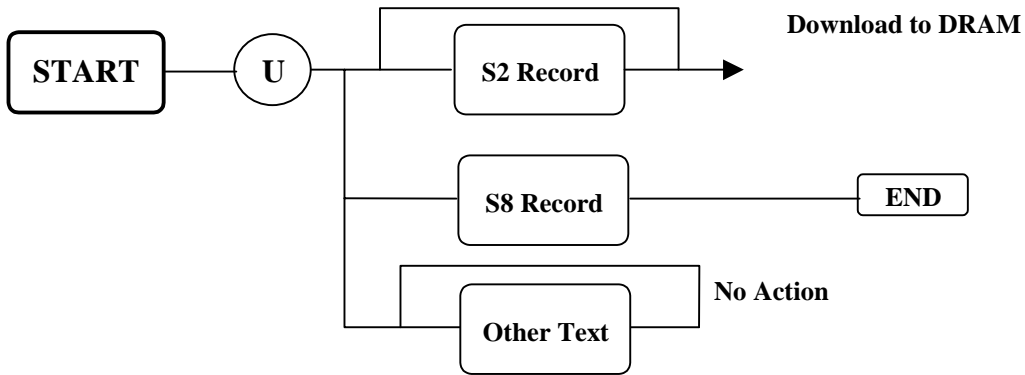

Figure 3-11 Download to DRAM Syntax Diagram

3.21 EXECUTE USER PROGRAM

To execute DRAM software, the first character of the data string is **J**. The remaining section of the command string is **R**. Refer to figure 3-4 Top Level Syntax Diagram.

Execute DRAM Software

R<nnnnnn> <nnnnnn> = Six hexadecimal characters defining the start address of the user software to be executed.

NOTE

No checks are performed on download address or execution address so in theory data may be downloaded anywhere. Western Avionics reserves the area \$20000 - \$5FFFF for user and guarantees not to use it in future enhancements of the Model 2700 family.

3.22 Status Reporting

SURETEST 2704 implements the status reporting structure defined by IEEE488.2
 An overall summary of the status structure is as shown below:

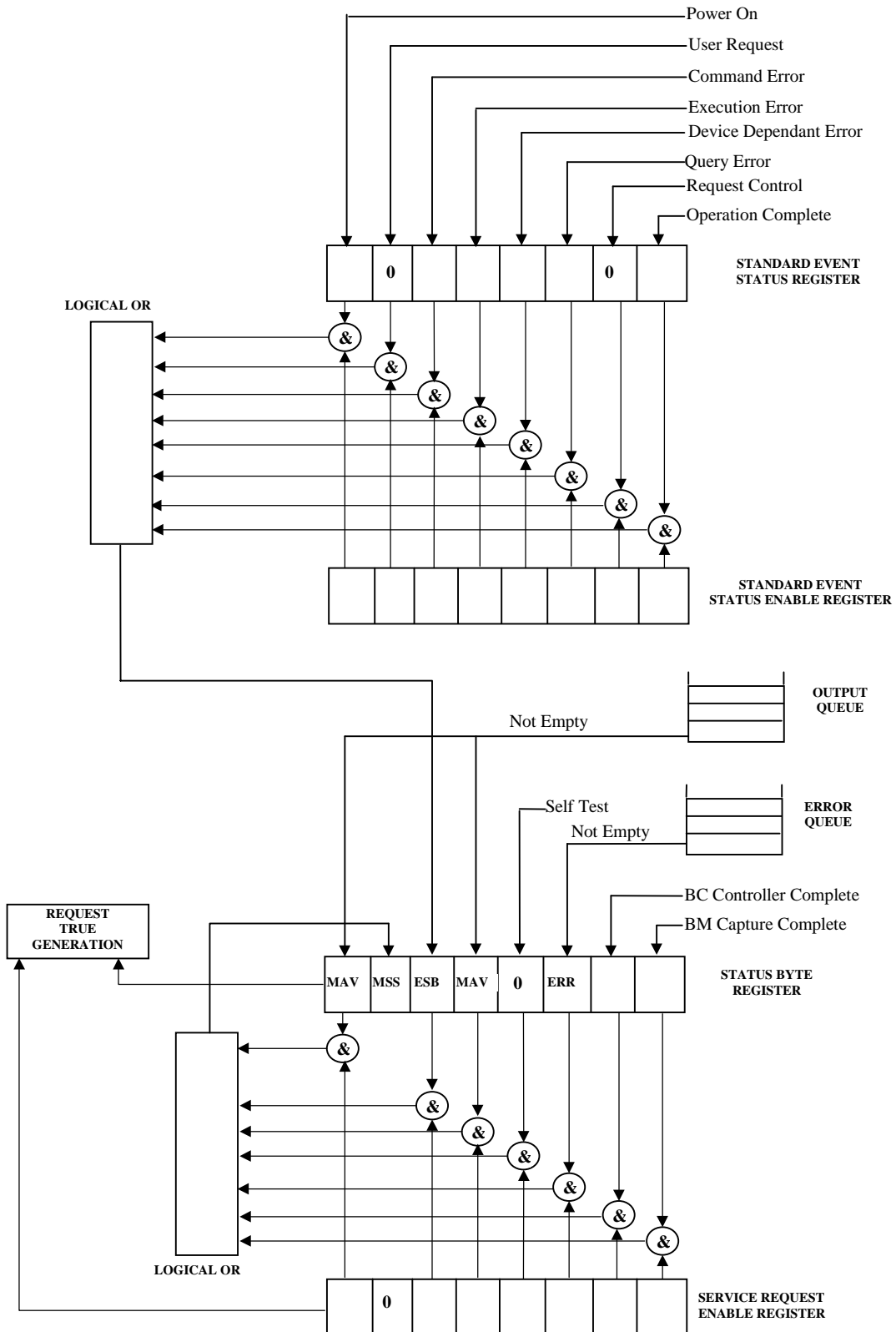

Figure 3-12 Status Reporting Structure Diagram

3.22.1 Status Byte Register

The Status Byte Register is the highest level of status reporting provided by SURETEST 2704. It is an 8-bit value, which can be returned to the commander by either of two methods. The commander can issue a VXI ReadSTB command to SURETEST 2704 or the commander can send a message containing the common command *STB? via the word serial protocol and read the response via the word serial protocol. The commander can issue a ReadSTB command at any time and read the response, independent of the state of the message exchange protocol.

The individual bits of the status byte register are:

Bit 0	BM	Bus Monitor Capture Complete. This bit is set after SURETEST 2704 Bus Monitor has completed capturing bus traffic and has become idle. The bit is an event indication, after the status byte is read it is cleared to zero.
Bit 1	BC	Bus Controller Complete. This bit is set after SURETEST 2704 Bus Controller has completed its transmission of bus traffic and has become idle. The bit is an event indication, after the status byte is read it is cleared to zero.
Bit 2	ERR	Error Queue not Empty. This bit is Set when one or more error messages are in the error queue.
Bit 3	ST	Set when SURETEST 2704 fails (non fatally) its self test.
Bit 4, 7	MAV	Message Available. This is set when one or more data bytes are in the output queue ready for the commander to read via the word serial protocol. This bit is duplicated for compatibility with older Westinghouse products.
Bit 5	ESB	Event Status Bit. This is set when one or more bits of the Standard Event Status Register are set and enabled.
Bit 6	MSS	Master Summary Status. This is set when SURETEST 2704 has a reason for requesting service. This occurs when one or more bits of the status byte are set and enabled.

3.22.2 Service Request Enable Register

The Service Request Enable Register is an 8 bit register which controls which bits of the status byte will cause SURETEST 2704 to send the **Request True** signal to the commander. The Service Request Enable Register is written and read by the common commands *SRE and *SRE?.

When a bit in the Service Request Enable Register and the corresponding bit in the status byte are both 1, the MSS bit in the status byte will be set and SURETEST 2704 will send the **Request True** signal to the commander. This is a form of interrupt whereby SURETEST 2704 is informing the commander of some event that requires attention. This is analogous to the "service request" function on IEEE488.1 GPIB instruments.

Bit 6 of the Service Request Enable Register, corresponds to the MSS bit of the status byte and is always read as zero and is ignored when written to.

3.22.3 Request True Generation

The Request True Generation block is responsible for sending both the Request True and the **Request False** signals to the commander. Whenever the result of a logical AND of a bit in the Status Byte Register, and the corresponding bit in the Service Request Enable Register changes from a zero to one, then there is a reason for SURETEST 2704 to request service by sending the **Request True** signal to the commander.

If, however, the most recent **Request True** signal sent to the commander had not been acknowledged by the commander reading the status byte, then the request true generation block will not send the **Request True** signal.

When the MSS bit of the status byte changes from one to zero then there are no longer reasons for SURETEST 2704 to request service. The request true generation block will in this situation send the **Request False** signal to the commander if the most recent **Request True** signal had not been acknowledged by the commander. This is to inform the commander that whatever action it took, although it did not read the status byte, was adequate to service SURETEST 2704. An example would be if the MAV bit was enabled to request service and the commander, without checking the status byte, emptied the output queue. That action was sufficient to clear the request for service.

3.22.4 Standard Event Status Register

The Standard Event Status Register is a 16 bit register which can be read by the commander using the common command *ESR? and reading the response from the output queue. It is an event register and as such, all bits are cleared after the register is read. The individual bits of the Standard Event Status Register are:

Bit 0	OPC	Operation Complete. This is set after the *OPC command has been sent to SURETEST 2704 and all pending operations are complete, including all overlapped commands.
Bit 1	RQC	Request Control. Always zero on SURETEST 2704.
Bit 2	QYE	Query Error. This is set after the commander sends a message containing a query and then violates the message exchange protocol.~
Bit 3	DDE	Device Dependent Error. This is set after an error occurs which is neither a Command Error, a Query Error, nor an Execution Error.
Bit 4	EXE	Execution Error. This is set after SURETEST 2704 detected an error during execution of a command sent from the commander.
Bit 5	CME	Command Error. This is set after SURETEST 2704 detected a syntax error in a command sent from the commander
Bit 6	URQ	User Request. Always zero on SURETEST 2704.
Bit 7	PON	Power On. This is set after an off to on transition occurs in the power supply to SURETEST 2704.

Bits 8 to 15 are reserved by IEEE for possible future use and are always reported as zero.

3.22.5 Standard Event Status Enable Register

The Standard Event Status Enable Register is a 16 bit register which controls which bits of the Standard Event Status Register will cause the ESB (Event Status Bit) in the status byte to be set. The Standard Event Status Enable Register is written and read by the common commands *ESE and *ESE?.

When the logical AND of any bit in the Standard Event Status Enable Register with the corresponding bit in the Standard Event Status Register is one, then the ESB bit in the status byte is set, otherwise the ESB bit is clear.

3.22.6 Error Queue

The error queue is a first in, first out structure, which holds information about error information. As SURETEST 2704 detects errors it adds them into the queue and sets an appropriate bit in the Standard Event Status Register. The queue can hold 16 entries. When the queue is not empty, the ERR bit in the status byte is set.

The contents of the queue can be read using the ERR? query, which returns the next item from the queue.

3.23 COMMON COMMANDS

Refer to figure 3-4 Top Level Syntax Diagram along with the following sub-paragraphs.

3.23.1 *CLS Command

The *CLS (clear status) common command clears the status reporting data structures.

The standard event status register is cleared to zero.

The error queue is cleared of all entries.

The status byte (except for the MAV bit) is cleared to zero.

If the *CLS command is the first command in a message, the output queue and the MAV bit in the status byte are also cleared.

Should SURETEST 2704 have requested service, via a **Request True** signal which had not been acknowledged at the time of the *CLS command, then SURETEST 2704 will send the **Request False** signal to the commander.

3.23.2 *ESE Command

The *ESE (Event Status Enable) common command sets the Standard Event Status Enable Register bits.

The Standard Event Status Enable Register contains a mask value for the bits to be enabled in the Standard Event Status Register. A one in the Standard Event Status Enable Register will enable the corresponding bit in the Standard Event Status Register, a zero will disable the bit. The effect of enabling a bit is to permit that event to set the Event Summary Status bit in the status byte and, possibly, generate a request for service to the commander.

The single parameter is rounded to an integer and must lie in the range 0 to 255 decimal.
The bit weights are:

Weight	Bit	Event Masked	
128	7	PON	Power On
64	6	URQ	N/A on 2704
32	5	CME	Command Error
16	4	EXE	Execution Error
8	3	DDE	Device Dependent Error
4	2	QYE	Query Error
2	1	RQC	N/A on 2704
1	0	OPC	Operation Complete

The *ESE? command returns the value of the Standard Event Status Enable Register.

3.23.3 *ESR? Command

The *ESR? (Event Status Register) common command returns the contents of the Standard Event Status Register into the output queue. The returned value is in the range 0 to 255.
This clears the Standard Event Status Register.

The returned parameter is a numeric data in the range 0 to 255 decimal.

3.23.4 *IDN? Command

The *IDN? (Identification Number) common command returns identification information about SURETEST 2704 into the Queue. It returns the string:

Westinghouse Shannon Ireland, Model 2704/2/3,0,V. cc.bb.rr.mm

Where cc.bb.rr.mm is the firmware revision levels, cc is revision level of CPU software, bb is revision level of BC, rr is revision level of RT and mm is revision level of BM.

3.23.5 OPC Command

The *OPC (Operation Complete) common command will cause SURETEST 2704 to set the OPC bit in the Standard Event Status Register when all pending commands have finished.

The query form, *OPC? will cause SURETEST 2704 to write an ASCII "I" into the output queue when all pending commands have finished. This query must be the last item in a message. As SURETEST 2704 has no overlapping commands, these commands execute immediately.

3.23.6 *STB? Command

The *STB? (Status Byte) common command returns the contents of the Status Byte into the output queue. The returned value is in the range 0 to 255. The value returned is the same as using the low level VXI word serial protocol command ReadSTB and is analogous to the serial poll in an IEEE488.1 GPIB system.

Reading the status byte clears bits 0 and 1 (the BC & BM complete) bits.

3.23.7 *WAI Command

The *WAI (Wait) common command causes SURETEST 2704 to stop executing further commands until all pending commands, including overlapped commands, have completed. As there are no overlapping commands, this command has no effect other than a very short delay.

3.24 CHANGE OPERATING MODE

- Q,A** Changes to 1553A mode and reinitialises hardware.
- Q,B** Changes to 1553B mode and reinitialises hardware.
- Q,R** Causes the board's selftest to be performed after which the values in memory are set to their default conditions (as described in paragraph 2-5). This takes about four seconds. If selftest fails then the RED led will light.
- *RST** IEEE 488.2 reset command sets the instrument to the default mode.
- *TST?** Causes the board's selftest to be performed after which the values in memory are set to their default conditions (as described in paragraph 2-5). This takes about 4 seconds. If selftest fails then the RED led will light.

The selftest result is returned.

Zero => Pass
Non-Zero => Fail

Change Operating Modes Syntax Diagram is as shown below.

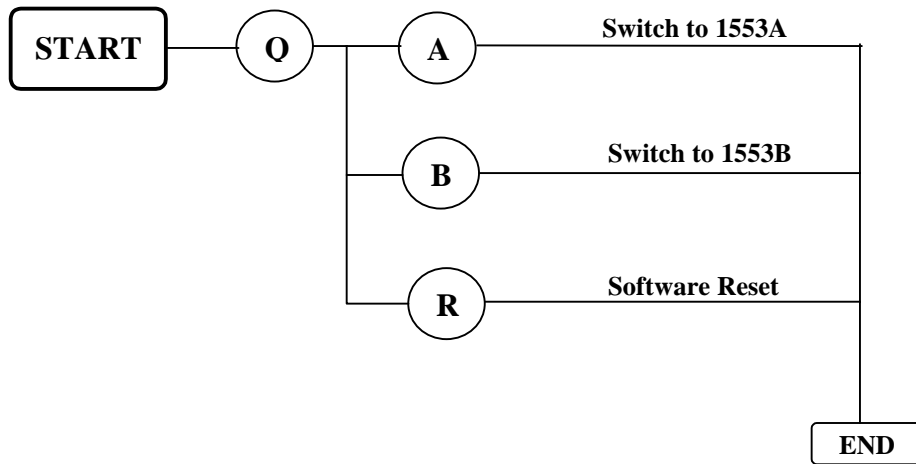

Figure 3-13 Change Operating Modes Syntax Diagram

3.25 FRAME RELATED COMMANDS

The Bus Controller can be run in two mutually exclusive modes, free frame and fixed frame.

Free frame is the default mode of operation. In free frame mode, the Bus Controller transmits all the messages defined in its link page until the first zero entry occurs. (Refer to example 1).

Specific commands must be called by the user to operate in fixed frame mode. In fixed frame mode the Bus Controller transmits all the messages defined in its link page (until the first zero entry occurs) within a given time period. (Refer to examples 2 and 3). A frame/cycle is composed of one or more minor frames/minor cycles. The terms frame and cycle are interchangeable.

The user can define a number of minor frames (free or fixed) within the link page and transmit only some of them if required. (See examples 4 and 5). The user can define a number of frames in the link page, but must not exceed the maximum number of entries. (Refer to example 6).

To exit fixed frame mode to return to the default free frame mode requires the use of specific commands which cancel the fixed frame setup. (See example 7).

F,C,<n>,<m>

This command splits up the link page allowing the user to define a number of minor frames "n" each containing a maximum of "m" link page entries. There must be at least one zero terminator entry at the end of each minor frame. The number of messages in each minor frame can be varied by adding in more than one zero terminator entry (Refer to example 8). However each minor frame must have at least one message, a blank minor frame is not possible.

"n" and "m" have a range of 1- 32767. However $n * m$ must not be greater than the default link page size of 320 entries. If a link page greater than 320 entries is required then it must be configured using the command CBL before the F,C, command is called.

The Frame will start from position zero in the link page (unless the F,S, command otherwise specifies).

F,C,0,0

This command is a special case. It restores the Bus Controller to the default mode of operation.

NOTE: The parser requires commas for this command.

F,L,<t>

This is the minor frame length function. This command must be called to use the fixed frame mode of operation. It determines the duration of the string of messages defined in the link page. The end of the link page is the first zero terminator entry. The intermessage gap of the last message is varied such that the total duration of the message string is "t" mS.

"t" is in mS and has a range of 0-65.

- F,L,0** This is a special case. It allows the VXI Word Serial Protocol "Trigger Command" to initiate a minor frame. Additionally the Model 2703 can be triggered by an external hardware trigger. The **F,L,0** command must be called after the **F,C,..** command.
(Refer to example 9).
- F,V** Cancels effect of F,L command.
- F,S,<p>** Sets the start of the frame to link position "p".
This allows the user to change the start position in the link page.

EXAMPLE;

NOTE 1: All the following examples require these six commands to setup the BC pages.

```
"B001C01N1111"
"B002C0IN2222"
"B003C0IN3333"
"B004C0IN4444"
"B00SC0IN5555"
"B006C0IN6666"
```

NOTE 2: For demonstration purposes it is not necessary to enable the Remote Terminal. This will not affect the example, however, no status word will be looked for in the results at the end of the example.

NOTE 3: The results are retrieved using the Transmit Bus Monitor Data command

```
"T+0000100014"
```

Example 1

Setup the Bus Controller to transmit a free frame containing six messages.

```
"B1L0,1,L1,2,L2,3,L3,4,L4,5,L5,6"
"LM"
"LBO"
```

```
= Setup the Link Page.
= Load and Run Monitor.
= Transmit Forever.
```

Results:

FF02 0821 0000,	CMD 01 R 01 01
0000 11114800,	DATA 1111
	IMG 1013uS
03F5 0821 0100,	CMD 01 R 01 01
0000 2222 4800,	DATA 2222
	IMG 1013uS
03F5 0821 0100,	CMD 01 R 01 01
0000 3333 4800,	DATA 3333
	IMG 1013uS
03F5 08210100,	CMD 01 R 01 01
0000 4444 4800,	DATA 4444
	IMG 1013uS
03F5 08210100,	CMD 01 R 01 01
0000 5555 4800,	DATA 5555
	IMG 1013uS
03F5 0821 0100,	CMD 01 R 01 01
0000 6666 4800,	DATA 6666

Example 2

Setup a fixed frame, which contains one minor frame containing six messages transmitted within a 20mS time period.

"B1L0,1,L1,2,L2,3,L3,4,L4,5,L5,6"	= Setup the Link Page.
"F,L,20"	= Minor Frame Time is 20mS.
"LM"	= Load and Run Monitor.
"LBO"	= Transmit Forever.

Results:

Minor Frame 1	FF02 08210000,	CMD	01 R 01 01	
	0000 1111 4800,	DATA		1111
		IMG		1013uS
	03F5 0821 0100,	CMD	01 R 01 01	
	0000 2222 4800,	DATA		2222
		IMG		1013uS
	03F5 0821 0100,	CMD	01 R 01 01	
	0000 3333 4800,	DATA		3333
		IMG		1013uS
	03F5 0821 0100,	CMD	01 R 01 01	
	0000 4444 4800,	DATA		4444
		IMG		1013uS
	03F5 0821 0100,	CMD	01 R 01 01	
	0000 5555 4800,	DATA		5555
		IMG		1014uS
	03F6 0821 0100,	CMD	01 R 01 01	
	0000 6666 4800,	DATA		6666
		IMG		14702uS
Minor Frame 1	396E 0821 0100,	CMD	01 R 0101	
	0000 1111 4800,	DATA		1111

Example 3

Setup a fixed frame containing three minor frames each containing two messages

Minor Frame 1: Messages 1 and 2

Minor Frame 2: Messages 3 and 4

Minor Frame 3: Messages 5 and 6

"B1L0,1,L1,2,L2,0,L3,3,L4,4,L5,0,L6,5,L7,6,L8,0" = Setup the link page.

"F,C,3,3" = Three Minor Frames each with Three Link Page Entries.

"F,L,20" = Minor Frame Time is 20mS.

"LM" = Load and Run Monitor.

"LBO" = Transmit Forever.

Results:

Minor Frame 1	FF02 0821 0000, 0000 1111 4800,	CMD 01 R 01 01 DATA 1111 IMG 1013uS
	03F5 0821 0100, 0000 2222 4800,	CMD 01 R 01 01 DATA 2222 IMG 18909uS
Minor Frame 2	49DD 08210100, 0000 3333 4800,	CMD 01 R 0101 DATA 3333 IMG 1013uS
	03F5 0821 0100, 0000 4444 4800,	CMD 01 R 01 01 DATA 4444 IMG 18909uS
Minor Frame 3	49DD 0821 0100, 0000 5555 4800,	CMD 01 R 0101 DATA 5555 IMG 1014uS
	03F6 0821 0100, 0000 6666 4800,	CMD 01 R 01 01 DATA 6666 IMG 18910uS
Minor Frame 1	49DE 08210100, 0000 1111 4800,	CMD 01 R 0101 DATA 1111

Example 4

Setup three minor frames but transmit the third one only. Transmit in free frame mode.

"BILO,I,L1,2,L2,0,L3,3,L4,4,L5,0,L6,5,L7,6,L8,0" = Setup the Link Page.
"F,S,6" = Adjust the Start Position.
"LM" = Load and Run Monitor.
"LBO" = Transmit Forever.

Results:

FF02 0821 0000, 0000 5555 4800,	CMD 01 R 01 01 DATA 5555 IMG 1014uS
03F6 0821 0100, 0000 6666 4800,	CMD 01 R 01 01 DATA 6666 IMG 1013uS
03F5 0821 0100, 0000 5555 4800,	CMD 01 R 01 01 DATA 5555 IMG 1013uS
03F5 0821 0100, 0000 6666 4800,	CMD 01 R 01 01 DATA 6666 IMG 1013uS
03F5 0821 0100, 0000 5555 4800,	CMD 01 R 01 01 DATA 5555

Example 5:

Setup three minor frames but transmit the second and third ones only. Transmit them once in fixed frame mode with a minor frame time of 20mS.

"B1L0,1,L1,2,L2,0,L3,3,L4,4,L5,0,L6,5,L7,6,L8,0" = Setup the Link Page.
"F,C,2,3" = Two Minor Frames each with Three Link Page Entries.
"F,L,20" = Minor Frame Time is 20mS.
"F,S,3" = Adjust the Start Position.
"LM" = Load and Run Monitor.
"LB2" = Transmit Two Minor Frames.

Results:

Minor Frame 2	FF02 08210000, 0000 3333 4800,	CMD 01 R 01 01 DATA 3333 IMG 1013uS
	03F5 0821 0100, 0000 4444 4800,	CMD 01 R 01 01 DATA 4444 IMG 18910uS
Minor Frame 3	49DE 0821 0100, 0000 5555 4800,	CMD 01 R 01 01 DATA 5555 IMG 1014uS
	03F6 0821 0100, 0000 6666 4800,	CMD 01 R 01 01 DATA 6666

Example 6

Setup two frames each containing two minor frames.

Frame 1 Minor Frame 1: Messages 1 and 2
 Minor Frame 2: Messages 3 and 4

Frame 2 Minor Frame 1: Messages 5 and 5
 Minor Frame 2: Messages 6 and 6

Transmit frame two only.

"B1L0,1,L1,2,L2,0,L3,3,L4,4,L5,0" = Setup frame 1
"BIL6,5,L7,5,L8,0,L9,6,L10,6,L11,0" = Setup frame 2
"F,C,2,3" = Two Minor Frames each with Three Link
 Page Entries.
"F,L,20" = Minor Frame Time is 20mS.
"F,S,6" = Adjust the start Position.
"LM" = Load and Run Monitor.
"LB0" = Transmit Frame 2 Continuously.

Results:

Frame 2; Minor Frame 1	FF02 08210000, 0000 5555 4800,	CMD 01 R 01 01 DATA 5555 IMG 1013uS
	03F5 0821 0100, 0000 5555 4800,	CMD 01 R 01 01 DATA 5555 IMG 18909uS
Frame 2; Minor Frame 2	49DD 0821 0100, 0000 6666 4800,	CMD 01 R 01 01 DATA 6666 IMG 1013uS
	03F5 0821 0100, 0000 6666 4800,	CMD 01 R 01 01 DATA 6666 IMG 18909uS
Frame 2; Minor Frame 1	49DD 0821 0100, 0000 5555 4800,	CMD 01 R 01 01 DATA 5555 IMG 1013uS
	03F5 0821 0100, 0000 5555 4800,	CMD 01 R 01 01 DATA 5555

Example 7

Setup a fixed frame containing three minor frames each containing two messages.

Minor Frame 1: Messages 1 and 2, Minor Frame 2: Messages 3 and 4,

Minor Frame 3: Messages 5 and 6

Transmit continuously then switch back to the default free frame mode.

"BILO,I,L1,2,L2,0,L3,3,L4,4,L5,0,L6,5,L7,6,L8,0"	= Setup the Link Page.
"F,C,3,3"	= Three Minor Frames each with Three Link Page Entries.
"F,L,20"	= Minor Frame Time is 20mS.
"LM"	= Load and Run Monitor.
"LBO"	= Transmit Forever.
"T+0000100014"	= Get Initial Results.
...	= Read Initial results
"F,C,0,0"	= Cancel the F,C,3,3 Command
"F,V"	= Cancel the F,L Command
"LM"	= Load & Run the Monitor
"T+0000100014"	= Get Final Results.
...	= Read Final Results

Initial Results:

Minor Frame 1	FF02 0821 0000, 0000 1111 4800,	CMD 01 R 01 01 DATA 1111 IMG 1013uS
	03F5 0821 0100, 0000 2222 4800,	CMD 01 R 01 01 DATA 2222 IMG 18909uS
Minor Frame 2	49DD 0821 0100, 0000 3333 4800,	CMD 01 R 0101 DATA 3333 IMG 1013uS
	03F5 0821 0100, 0000 4444 4800,	CMD 01 R 01 01 DATA 4444 IMG 18909uS
Minor Frame 3	49DD 08210100, 0000 5555 4800,	CMD 01 R 0101 DATA 5555 IMG 1014uS
	03F6 0821 0100, 0000 6666 4800,	CMD 01 R 01 01 DATA 6666 IMG 18910uS
Minor Frame 1	49DE 08210100, 0000 1111 4800,	CMD 01 R 01 01 DATA 1111

Final Results:

Minor Frame 1	FF02 0821 0000, 0000 2222 4800,	CMD 01 R 01 01 DATA 2222 IMG 1013uS
	03FS 0821 0100, 0000 11114800,	CMD 01 R 01 01 DATA 1111 IMG 1013uS
	03FS 0821 0100, 0000 2222 4800,	CMD 01 R 01 01 DATA 2222 IMG 10131uS
Minor Frame 1	03FS 0821 0100, 0000 1111 4800,	CMD 01 R 01 01 DATA 1111 IMG 1014uS
	03F6 0821 0100, 0000 2222 4800,	CMD 01 R 01 01 DATA 2222

Example 8

Setup a fixed frame containing two minor frames each containing a different number of messages.

Minor Frame 1: Message 1

Minor Frame 2: Messages 2,3,4

"B1L0,1,L1,0,L2,0,L3,0,L4,2,L5,3,L6,4,L7,0" = Setup the Link Page.

"F,C,2,4" = Two Minor Frames each with Four Link Page Entries.

"F,L,20" = Minor Frame Time is 20mS.

"LM" = Load and Run Monitor.

"LBO" = Transmit Forever.

Results:

Minor Frame 1	FF02 0821 0000, 0000 1111 4800,	CMD 01 R 01 01 DATA 1111 IMG 19961Us
Minor Frame 2	4DF9 0821 0100, 0000 2222 4800,	CMD 01 R 01 01 DATA 2222 IMG 1013uS
	03FS 0821 0100, 0000 3333 4800,	CMD 01 R 01 01 DATA 3333 IMG 1013uS
	03F5 0821 0100, 0000 4444 4800,	CMD 01 R 01 01 DATA 4444 IMG 17857uS
Minor Frame 1	45CI 0821 0100, 0000 1111 4800,	CMD 01 R 01 01 DATA 1111 IMG 19961uS
Minor Frame 2	49DF 0821 0100, 0000 2222 4800,	CMD 01 R 0101 DATA 2222 IMG 1013uS
Minor Frame 1	03FS 0821 0100, 0000 3333 4800,	CMD 01 R 0101 DATA 3333

Example 9

Setup a fixed frame containing three minor frames each containing two messages.

Minor Frame 1: Messages 1 and 2
Minor Frame 2: Messages 3 and 4
Minor Frame 3: Messages 5 and 6

Transmit a minor frame each time the VXI (WSP) Trigger Command occurs.

"B1L0,1,L1,2,L2,0,L3,3,L4,4,L5,0,L6,5,L7,6,L8,0" = Setup the Link Page.

"F,C,3,3" = Three Minor Frames each with Three Link Page Entries.

"F,L,0" = Wait for VXI (WSP) Trigger.

"LM" = Load and Run Monitor.

"LB0" = Transmit Forever.

... Send VXI (WSP) Trigger Command = Transmit One Minor Frame

|

Results:

Minor Frame 1	FP02 08210000, 0000 11114800,	CMD 01 R 01 01 DATA 1111 IMG 1013uS
	03F5 0821 0100, 0000 2222 4800,	CMD 01 R 01 01 DATA 2222

3.26 CONFIGURATION COMMANDS

C,B,M,<m> Configures the maximum number of different messages which may be defined in BC. Maximum value **401**. The power on default is **320**.

C,B,L,<n> Configures the maximum number of link page entries which may be defined in BC. This must be between **1** and **30000**. The default is **320**.

The above two commands are subject to memory limitations. For a link page up to 509 entries the number of BC pages may be set as high as 401. For a link page greater than 509, the m,n parameters must satisfy the inequality.

$$160*m + 2*n < 64304$$

An error is generated if an attempt is made to violate the above condition.

The commands **C,B,M?** and **C,B,L?** return the current settings as a decimal number. Refer to figure 3-4 Top Level Syntax Diagram.

3.26.1 ERR? Command

The ERR? command is a query only which removes a single entry from the error queue and places the text into the output queue. The error queue is a first in, first out queue, added to as errors are reported. If the error queue overflows, the last error in the queue is replaced with error -350. The error queue holds 16 entries.

When an error is reported, the error number and some device dependent information is put into the queue.

Error numbers in the range -100 to -199 are command errors and, when reported set the CME bit in the Standard Event Status Register.

Error numbers in the range -200 to -299 are execution errors and, when reported set the EXE bit in the Standard Event Status Register.

Error numbers in the range -300 to -399 are device dependent errors and, when reported set the DDE bit in the Standard Event Status Register. The exception here is error -350, Queue overflow, which does not set DDE.

Error numbers in the range -400 to -499 are query errors and, when reported set the QYE bit in the Standard Event Status Register.

Error number 0 is returned when the queue is empty.

The response to the ERR? command is two data items; the error number and a string describing the nature of the error. See paragraph 3.24.1.1.

3.26.2 Error Numbers and Descriptions

The format of the returned data is:

<err#>,"<Error Description>;<Device Dependent Information>"

Where the error is a syntax or similar error in a command or query message, the device dependent information field is a repeat of the offending portion of the message with an arrow head (->) pointing to the item which SURETEST 2704 considers an error.

Where the error is due to some other reason, the device dependent information field contains extra textual information describing the nature of the problem.

The possible Error numbers returned by SURETEST 2704 and associated descriptions are listed below. Comments about possible causes are in square brackets [] and are NOT returned by SURETEST 2704.

Error Number	Description
0	No error [The queue is empty. Either all errors have been read or the queue cleared by *CLS or power on]
-100	Command error [A syntax error]
-225	Out of memory [SURETEST 2704 has insufficient memory to complete command]
-350	Queue overflow [The error queue has overflowed. At least one error has occurred which is not recorded in the queue]
-410	Query INTERRUPTED [The message exchange protocol has been violated]
-420	Query UNTERMINATED [The message exchange protocol has been violated]
-430	Query DEADLOCKED [The message exchange protocol has been violated]
-440	Query UNTERMINATED after indefinite response [A query was received in the same message after a query requesting an <ARBITRARY ASCII RESPONSE> element]

SECTION III. WORKED APPLICATION EXAMPLES

3.27 INTRODUCTION

The following paragraph contains worked application examples for programs. Figures 3-14 through 3-16 are examples of programs.

3.28 PROGRAM EXAMPLE

This example shows how to set up the Bus Controller, a Remote Terminal and a Bus Monitor. The Bus Controller will ask Remote Terminal 8, Sub-address 2 to transmit 3 words of data AAAA, BBBB, and CCCC on the Secondary Bus and the whole transaction will be recorded by the Monitor.

Step 1

Bus Controller;

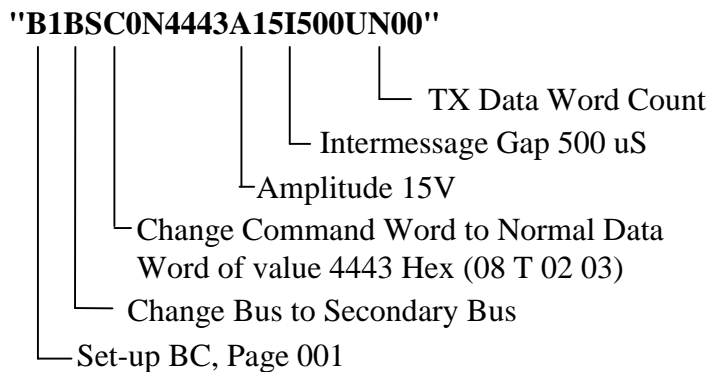

Figure 3-14 Example BC Page 001 (part 1)

Step 2

Remote Terminal;

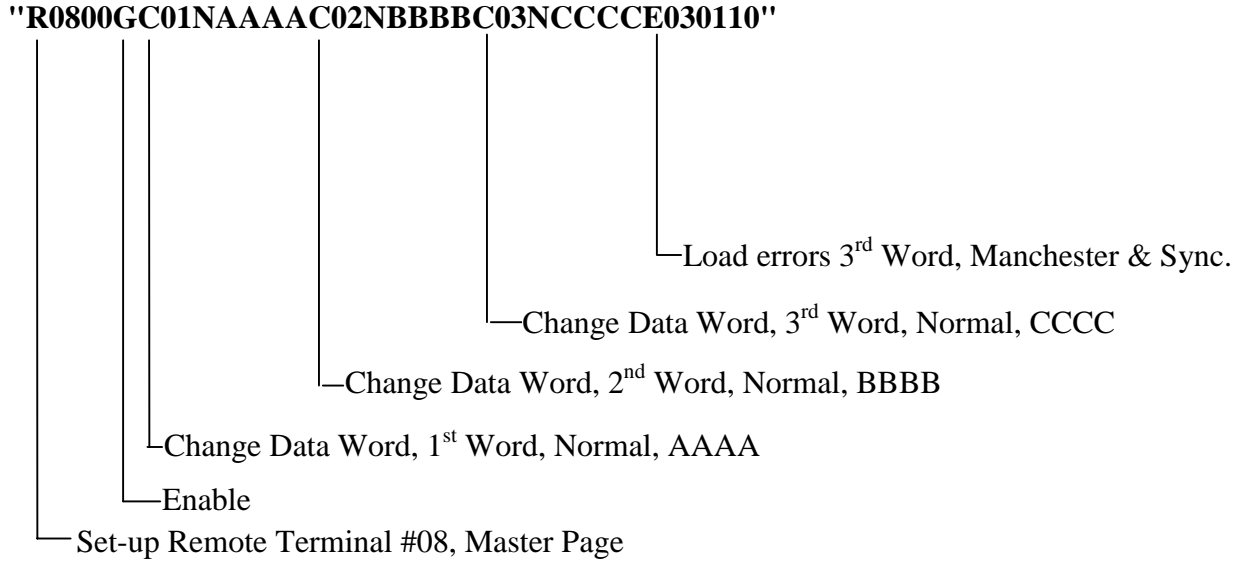

Figure 3-15 Example RT 08 (part 1)

Step 3

Monitor Data:

- "LR" Run Remote Terminal
- "LM" Run Monitor.
- "LBO" Transmit Forever.
- T+1,7" Retrieve 7 Bus Words.

Result;

FF02 4443 2000	CMD 08 T 02 03
0203 4443 2100	
0004 4000 3000	Status 08 0 00 00
0000 AAAA 6800	Data AAAA
0000 BBBB 6800	Data BBBB
0000 CCCC 2C08	Data CCCC with Mn error
01F4 4443 2000	Repeat

Step 4

Change Trigger

Now the Trigger is changed so that the Monitor will trigger on a data word with Manchester error...namely CCCC.

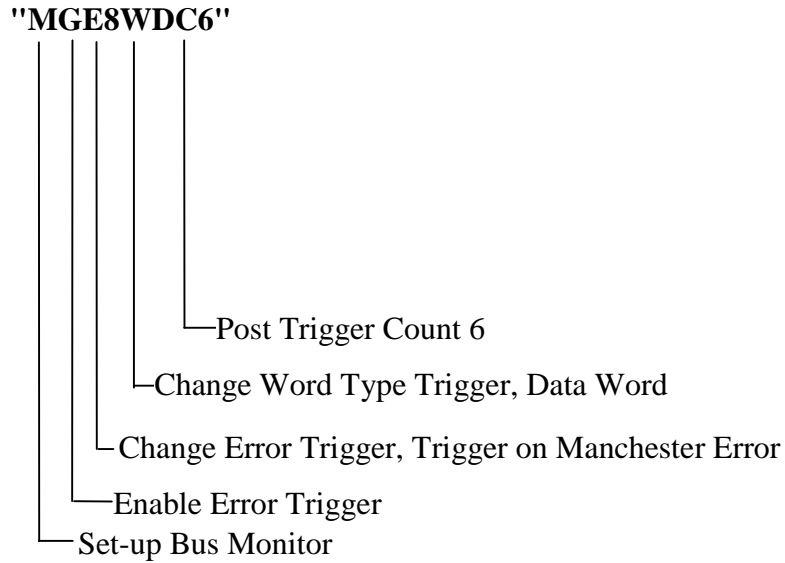

Figure 3-16 Example Bus Monitor Trigger Condition

Step 5

Monitor Data:

"LM" Run Monitor.

"T+1,6" Retrieve 6 Bus Words.

Result;

0000 CCCC 2C08	Data with Mn error
01F5 4443 2000	CMD 08 T 02 03
0004 4000 3000	Status
0000 AAAA 6800	Data AAAA
0000 BBBB 6800	Data BBBB
0000 CCCC 2C08	Data CCCC with Mn error

NOTE

The trigger occurred with the only data word having a Manchester error, namely CCCC.

APPENDIX A
DEFAULT MODE CODE RESPONSES
MIL-STD-1553A

Mode Code	Mode Code	Mode Code Response
00	D	Dynamic Bus Control Acceptance
01	R	Reserved
02	R	Reserved
03	R	Reserved
04	R	Reserved
05	R	Reserved
06	R	Reserved
07	R	Reserved
08	R	Reserved
09	R	Reserved
0A	R	Reserved
0B	R	Reserved
0C	R	Reserved
0D	R	Reserved
0E	R	Reserved
0F	R	Reserved
10	R	Reserved
11	R	Reserved
12	R	Reserved
13	R	Reserved
14	R	Reserved
15	R	Reserved
16	R	Reserved
17	R	Reserved
18	R	Reserved
19	R	Reserved
1A	R	Reserved
1B	R	Reserved
1C	R	Reserved
1D	R	Reserved
1E	R	Reserved
1F	R	Reserved

APPENDIX B DEFAULT MODE CODE RESPONSES MIL-STD-1553B

Mode Code	Mode Code Response	Mode Code Response
00	D	Dynamic Bus Control Acceptance
01	J	Just Status
02	J	Just Status
03	J	Just Status
04	J	Just Status
05	J	Just Status
06	J	Just Status
07	J	Just Status
08	J	Just Status
09	R	Reserved
0A	R	Reserved
0B	R	Reserved
0C	R	Reserved
0D	R	Reserved
0E	R	Reserved
0F	R	Reserved
10	W	Status + Data Word (AAAA)
11	R	Reserved
12	T	Status + Transmit Last Command
13	W	Status + Data Word (BBBB)
14	R	Reserved
15	R	Reserved
16	R	Reserved
17	R	Reserved
18	R	Reserved
19	R	Reserved
1A	R	Reserved
1B	R	Reserved
1C	R	Reserved
1D	R	Reserved
1E	R	Reserved
1F	R	Reserved

APPENDIX C MIL-STD-1553B ASSIGNED MODE CODE RESPONSES

Trans RX Bit	MC Hex	Mode Code	Function	Assoc. Data Word	B/Cast Cmnd Allowed
1	00	00000	Dynamic Bus Control	No	No
1	01	00001	Synchronise	No	Yes
1	02	00010	Transmit status word	No	No
1	03	00011	Initiate self-test	No	Yes
1	04	00100	Transmitter shutdown	No	Yes
1	05	00101	Override transmitter shutdown	No	Yes
1	06	00110	Inhibit terminal flag bit	No	Yes
1	07	00111	Override inhibit terminal flag bit	No	Yes
1	08	01000	Reset remote terminal	No	Yes
1	09	01001	Reserved	No	TBD
1	0A	01010	Reserved	No	TBD
1	0B	01011	Reserved	No	TBD
1	0C	01100	Reserved	No	TBD
1	0D	01101	Reserved	No	TBD
1	0E	01110	Reserved	No	TBD
1	0F	01111	Reserved	No	TBD
1	10	10000	Transmit vector word	Yes	No
0	11	10001	Synchronise	Yes	Yes
1	12	10010	Transmit last command	Yes	No
1	13	10011	Transmit bit word	Yes	No
0	14	10100	Selected transmitter shutdown	Yes	Yes
0	15	10101	Override selected transmitter shutdown	Yes	Yes
1 or 0	16	10110	Reserved	Yes	TBD
1 or 0	17	10111	Reserved	Yes	TBD
1 or 0	18	11000	Reserved	Yes	TBD
1 or 0	19	11101	Reserved	Yes	TBD
1 or 0	1A	11010	Reserved	Yes	TBD
1 or 0	1B	11011	Reserved	Yes	TBD
1 or 0	1C	11100	Reserved	Yes	TBD
1 or 0	1D	11101	Reserved	Yes	TBD
1 or 0	1E	11110	Reserved	Yes	TBD
1 or 0	1F	11111	Reserved	Yes	TBD

SP-J-403-E-1043 EFA STANAG 3838 PROTOCOL IMPLEMENTATION, (BC)

Mode Codes not required:

00110 Inhibit terminal flag bit
00111 Override inhibit terminal flag bit
10100 Selected transmitter shutdown
10101 Override selected transmitter shutdown

Note: BC shall only transmit Mode Commands using 1111 in Mode/Subaddress field of the Command Word.

SP-J-403-E-1044 EFA STANAG 3838 PROTOCOL IMPLBMENTATION, (RT)

Mode Codes not required:

00000 Dynamic bus control
00110 Inhibit terminal flag bit
00111 Override inhibit terminal flag bit
10100 Selected transmitter shutdown
10101 Override selected transmitter shutdown

APPENDIX D

**BUS CONTROLLER, BUS MONITOR
ENHANCEMENTS
AND
SPECIALISED SELECTIVE CAPTURE (SSC)**

4 Bus Controller, Bus Monitor and SSC enhancements, Introduction

The following paragraphs define the enhancements made to the basic SURETEST 2704 functionality. These enhancements are for dynamic updating of the Bus Controller messages and for an enlarged Bus Monitoring capability. Further enhancements provide a Specialised Selective Capture (SSC) capability in Bus Monitoring mode of operation

4.1 APPLICABILITY

The Bus Controller and Bus Monitor enhancements apply along with Specialised Selective Capture (SSC) enhancements to all versions of the SURETEST 2701/2/3 (Western Avionics part numbers IU03597Gxx).

4.2 IMPLEMENTATION

The enhancements are implemented as extra commands sent via the VXI Word Serial Protocol to SURETEST 2701/2/3. At power up and after the reset command, the enhancements are disabled and there is no difference in behavior of SURETEST 2701/2/3. Control software designed for earlier versions of SURETEST 2701/2/3 will work without modification.

4.3 BUS CONTROLLER ENHANCEMENTS

The Bus Controller enhancements allow for dynamic updating of BC pages and for a transmission sequence to be extended beyond the original 60000 frames, up to a new limit of 4 294 967 295 frames / cycles. The applicable extra commands are:

DB<Binary Data>
l1

4.3.1 DB Command

The DB command downloads binary data to SURETEST 2701/2/3 defining the update sequence and data. There must be no character (not even a space) after the 'B' as SURETEST 2701/2/3 interprets all data up to the end of the message as pure binary records. SURETEST 2701/2/3 interprets the binary data as a sequence of records, each defining a message to update. It is not necessary for each DB command to contain an integral number of records but each DB command must be less than 4096 bytes in length. A large update sequence must be sent as a series of DB commands.

Each record consists of a four-byte header followed by a number of data bytes. The number of bytes is defined within the header. Where two data bytes are interpreted as a WORD, the most significant byte is the first byte; the least significant byte is the second byte. Motorola format is used.

The record header is:

<Message Number>	(WORD)
<Index>	(BYTE)
<Count>	(BYTE)

The <Message Number> is the BC page number that will be updated by the record. It may range from one (1) to the largest permissible BC page number (320 by default unless altered by using the CBM command). SURETEST 2701/2/3 does no checking of the validity of this value. An erroneous value will cause unpredictable consequences.

The <Index> is the number of the 1st data word of the message that will be updated. A value of zero indicates the command word, 1 is the first data word, 32 the last data word. As with the <Message Number> SURETEST 2701/2/3 does no checking of the validity of the <Index>. A value greater than 32 may cause unexpected side effects.

The <Count> is the number of WORDS that are to be updated, these follow the header. The <Count> may range from 1 to 33 and as with the other parameters SURETEST 2701/2/3 performs no validity checking. An erroneous value may cause unexpected side effects.

The data follows the header as a sequence of WORDs.

Each 'DB' command received by SURETEST will cause SURETEST 2701/2/3 to append the binary data to existing data in SURETEST 2701/2/3.

4.3.2 I1 Command

The I1 command enables the dynamic update mode. It performs some processing on the records downloaded by the 'DB' command, converting the header data to an internal format.

In the dynamic update mode, SURETEST 2701/2/3 processes the data in the 'DB' records on a record-by-record basis. After the message number specified by the record is transmitted the data in the record is copied to the BC message, starting at the specified index word; the number of words copied being specified by the Count parameter. The next record is then processed.

The list of records is considered as a circular list, the first record follows the last so that this dynamic update continues for as long as the BC is transmitting.

The dynamic update remains in force after the BC stops transmitting (either because of the 'HB' command or as a result of the pre-programmed number of frames / cycles being transmitted). A subsequent 'LBxx' command will cause record processing to start at the first record in the list.

Restrictions

The I1 command should be used before the BC is started with the LB command. After the BC is halted, the BC message data will contain the most recent updated data. To repeat the most recent transmission sequence all the BC pages will need to be reinitialised with the initial data.

The I1 command must be used before the 'I2' command is sent.

4.3.3 LB Command

The LB command is enhanced to allow values from 0 to 4 294 967 295 decimal. A value of zero indicates 'forever'.

4.3.4 Error Reporting

The 'DB' and 'I1' commands report errors using the normal SURETEST 2701/2/3 reporting mechanism. The possible errors are:

-225 "Out of memory; DRAM capacity exceeded"

The DB command reports this error when more than 902264 bytes have been downloaded.

-200, "Execution error; I1 abort - part block found" .

The I1 command reports this error if during its processing it finds that the last record is not complete (the specified count does not match the actual number of bytes downloaded). It can occur due to the last block being either short or due to an error in one of the headers, causing subsequent records to be misinterpreted. This error prevents the dynamic update mode from being enabled.

-200, "Execution error; I1 abort - no data downloaded"

The I1 command reports this error if it detects less than three records have been downloaded. The dynamic update algorithm needs a minimum of three records to be able to work correctly.

5 BUS MONITOR ENHANCEMENTS

The Bus Monitor enhancements (Mode I) allow for a specialised selective capture mode with an enlarged buffer (up to 881K bytes) and a separate error reporting queue for errors encountered during the capture. The extra commands are:-

I2 <Command Word Mask>,<Status Word Mask>,<Error Filter>,<Flag>
DS?
DD? <Offset>,<Count>
DQ?

5.1 I2 Command

The I2 command specifies the operation of the selective capturing and initiates the Bus Monitor and is used in place of the 'LM' command to start the monitor while the 'HM' command is used to stop the monitor.

The <Command Word Mask> is a 16 character binary pattern, which may contain 0, 1, or 'X' for "don't care" bits. It is used as a filter for all command words (including RT to RT command words). When a message is encountered whose command word matches that specified, the data words (not status words) are stored in a circular DRAM buffer. No timing or error information is stored with these words.

The <Status Word Mask> is a 16 character binary pattern, which may contain 0,1, or 'X' for "don't care" bits. It is used to examine all status words. When a status word is encountered which does NOT match the specified pattern a record is added to a special error queue (see DS? command paragraph D-5.2).

The <Error Filter> is a hexadecimal number. It may not contain 'X' characters. All received bus words have their error word filtered by this value. The error word (specified in paragraph 3-16) is ANDed with the <Error Filter> and if the result is non zero, a record is added to a special error queue (see DS? command).

The <Flag> parameter controls whether the command word specified by the <Command Word Mask> is stored before the data words. This occurs when the <Flag> is non zero.

After the "I2" command is received the Bus Monitor starts monitoring messages and storing appropriate data. The size of DRAM buffer is automatically determined by SURETEST 2701/2/3 as all available memory. The maximum is 902264 bytes but this is reduced when "DB" commands have been received prior to the I2 command. When the buffer is full, storage continues at the start of the buffer overwriting the oldest captured data.

5.2 DS? Command

The DS? command returns a record from the special error queue consisting of either status or protocol errors. Each DS? reads a single record until the queue is exhausted. If the record is a status error (the status word did not match the <Status Word Mask>) of the "I2" command the returned data is:-

<Message Number>,S,<Status Word>

If the record is a protocol error (the error word ANDed with the <Error Filter>) of the "I2" command was non zero the returned data is:-

<Message Number>,D,<Error Word>,<Word Number>

where the <Error Word> is the full detected error word and <Word Number> is the offset into the message of the offending word. Zero is used for command and status words, the first data word of a message being word number 1.

In all cases, all numeric values are returned as decimal integers. The <Message Number> is a unique identifier assigned by SURETEST 2701/2/3. The first message monitored after the "I2" command is assigned an id of one. Subsequent messages are assigned id's in numeric ascending order. The id is a 32-bit number.

When the queue contains no more data the record 0,S,0 is returned to signify an empty queue.

Restriction

The DS? command must not be used while the Bus Monitor is running. Doing so may return erroneous data as pointers may be changing. The "HM" command should be used to stop the monitor first.

5.3 DD? Command

The DD? Command is used to read data from the circular DRAM buffer. The data is returned as ASCII HEX numbers each of four characters (with leading zeros if needed) and separated by commas.

The <Offset> is the starting location in the buffer (as a count of words) where reading commences. A value of zero is the oldest word in the buffer.

The <Count> is the number of words to read from the buffer. The actual number of words returned may be less than this if the <Offset> + <Count> exceeds the size of the buffer. In this case, the data returned ends with the most recently stored word.

Restriction

The DD? command must not be used while the Bus Monitor is running. Doing so may return erroneous data as pointers may be changing. The "HM" command should be used to stop the monitor first.

5.4 DQ? Command

The DQ? command returns status information about the current state of the special Bus Monitor mode initiated by the 'I2' command. Unlike the 'DS?' and 'DD?' commands it may be executed at any time, the returned data will be accurate at the point of execution of the command. The DQ? command returns four values, all decimal integers, separated by commas. These are:-

Buffer Size	The size of the DRAM buffer in WORDs.
Words in Buffer	The number of words so far captured in the DRAM buffer. (this will not exceed the Buffer Size value).
Error Count	The number of records in the special error queue. This will not exceed 8191 if an overlap occurs (older records being lost).
Message Count	The number of messages monitored since the 'I2' command.

5.5 Error Reporting

The 'I2', 'DS?' 'DD?' and 'DQ?' commands do not report any errors. Any parameter errors are detected by the parser as usual in SURETEST 2701/2/3.

When the monitor is stopped (by either the 'HM!' or 'I0' commands) the error: -

-200,"Execution error;l2 Error Queue Overflow"

is reported via the normal SURETEST 2701/2/3 error reporting mechanism if the special error queue had overflowed. Due to time constraints, it can not be reported as it happens.

6 DISABLING THE ENHANCEMENTS

The 'I0' command disables the enhancements. It takes no parameters. The 'I0' command will immediately halt the BC and BM (if running). It also discards all the data previously downloaded by the 'DB' command. Except for a '*RST' which is a full SURETEST 2701/2/3 reset this is the only method of clearing the data downloaded by the 'DB' command.

The 'I0' command has no effect on the monitor DRAM data nor the special error queue. These may still be read using the 'DS?' and 'DD?' commands.

7 PROGRAMMING CONSIDERATIONS

As SURETEST 2701/2/3 performs automatic memory management it is essential that commands are sent in the "correct" order when both the BC and BM enhancements are being used simultaneously. The order of execution should be:-

I0	/* Clears all data	*/
DB....		
DB...	/* Download data	*/
I2...	/* Start BM	*/
LBxx...	/* Start BC	*/
....		
....	/* Wait a while	*/
HM..	/* Stop BM, leaving BC running	*/
DS? or DD?	/* Read desired data	*/

The DQ? command can be used to periodically poll SURETEST 2701/2/3 to determine how many messages / data words / errors have been detected. The value returned is always little behind reality but is a reasonable approximation.

It should be noted that the dynamic update and BM enhancements use CPU time on an interrupt driven basis, allowing SURETEST 2701/2/3 to continue processing as normal while these tasks execute. However, the VXI word serial protocol is given priority over the BC dynamic update and BM processing. The VXI commander is allowed to be able to always get control of SURETEST 2701/2/3, but excessive VXI commands (example reading the status byte) may cause such a load on the CPU that the BC update or BM processing will fail.

Normal commands do not have this problem because although the VXI transfer takes priority the interpreting and execution is lower priority than anything else. It is still possible to alter simulated RT setups and BC page parameters (with the exception of the data, as this would have uncertain effects) while both enhancements are running.

The 'DB' command must be sent without extra characters at the end of the message (no carriage return / line feed). The VXI commander may need special programming or configuration to achieve this.

8 SPECLALISED SELECTIVE CAPTURE (SSC)

The following paragraphs define the specialised selective capture (SSC) enhancements that apply to all versions of the SURETEST 2701/2/3

9 SSG IMPLEMENTATION

The enhancements are implemented as extra commands sent via the VXI Word Serial Protocol to SURETEST 2701/2/3. At power up and after the reset command, the enhancements are disabled and there is no difference in behavior of SURETEST 2701/2/3. Control software designed for earlier versions of SURETEST 2701/2/3 will work without modification.

10 BUS MONITOR ENHANCEMENTS

When in the Specialised Selective Capture (SSC) mode (Mode 2) the SURETEST 2701/2/3 Bus Monitor runs in continuous record mode and records all 1553 bus traffic into a 64KByte circular buffer. When a block of 3,000 1553 words has been recorded the BM issues an interrupt and this block of data is scanned for trigger occurrences. If a trigger is found, the trigger word and a user defined number of post trigger words are copied into the A24 memory (a 64KByte circular buffer at \$200000). This buffer can be read via the VXI. All triggers in the A24 memory can be easily identified since the MSB of their associated error word is set to one (1). The total number of occurrences of each of the six triggers is calculated and can be examined by the user.

The user should note that triggers could also occur during **the post** trigger words of a previous trigger. In this case, the original post trigger count is aborted; the new trigger word is marked as before and is copied with its full number of post trigger words to the A24 memory. This ensures that: -

All trigger occurrences can be identified.
The stack is in chronological order.
All words associated with each trigger are recorded.
No words are recorded more than once.

Performance limitations are based on the bus loading. Trigger scanning takes approximately 60uS per 1553 word, thus the long term average traffic on the bus must be less than one word per 60uS. This rate may be exceeded in the short term provided there are never more than 6,000 bus words in any 180mS period. Since the Specialised Selective Capture BM enhancements use CPU time on an interrupt driven basis the card can continue processing as normal while these tasks execute. However, the VXI Word Serial Protocol is given priority over the Bus Monitor processing. This allows the VXI commander to always to be able to obtain control of SURETEST 2701/2/3 but excessive VXI commands may cause such a load on the CPU that the Bus Monitor processing will fail.

The additional commands are: -

```
ST<d> <Trigger Word Mask>,<Trigger Error Mask>,<Post Trigger Count>
S1
SQ?
SO
```

10.1 ST Command

The ST command enables the user to define the six triggers associated with the Specialised Selective Capture mode.

<d> is a single decimal character 1 to 6 defining which trigger is being set up.

<Trigger Word Mask> is a 16 character binary pattern which may contain '0', '1', or 'X' for "don't care" bits. It is used as a filter for all 1553 words recorded by the Bus Monitor.

<Trigger Error Mask> is a 16 character binary pattern, which may contain '0', '1', or 'X' for "don't care" bits. It is used as a filter for all 1553 words recorded by the Bus Monitor.

<Post Trigger Count> is the number of 1553 words which are stored on the Bus Monitor Stack following the 1553 trigger word which matched the Trigger Word Mask and the Trigger Error Word, valid range **0000** to **9999** decimal.

NOTE

All six triggers must be defined.

Trigger Error Mask = IXXXXXXXXXXXXXXXXX to disable a trigger.

All triggers must be assigned the same value of Post Trigger Count (ptc).

A ptc of zero copies only the trigger word to the A24 memory

10.2 S1 Command

The 'S1' command specifies the operation of the continuous selective capture mode and initiates the Bus Monitor. It is used in place of the 'LM' command to start the monitor. The 'SO' command is used to stop the monitor. The 'ST ...' command must be used to define the triggers before the 'S1' command is received.

When the 'S1' command is received the Bus Monitor starts monitoring all the messages and stores only those that match the Trigger definitions in the A24 memory at hex address \$200000. If this 64KByte buffer becomes completely full then it wraps around and continues storing over the oldest trigger data.

10.3 SQ? Command

The 'SQ?' command is used to periodically poll the SURETEST 2701/2/3 to determine how many trigger occurrences have been detected. The values returned may be a little behind reality if numerous triggers are occurring but they are a reasonable approximation.

The returned data is in the format:

```
T,1,<Number of Occurrences>;  
T,2,<Number of Occurrences>;  
T,3,<Number of Occurrences>;  
T,4,<Number of Occurrences>;  
T,5,<Number of Occurrences>;  
T,6,<Number of Occurrences>.
```

The <Number of Occurrences> is returned as a decimal value.

10.4 S0 Command

The 'S0' command disables the enhancements. It requires no parameters. The 'S0' command will immediately halt the Bus Monitor and scan any remaining Bus Monitor data for trigger information. It is important to execute this command to avoid the loss of trigger information.

11 PROGRAMMING CONSIDERATIONS

It is essential that commands be sent in the "correct" order when using the Specialised Selective Capture (SSC) mode. The order of execution is :-

```
ST1....    /* Define trigger 1          /*  
ST2...     /* Define trigger 2          /*  
ST3...     /* Define trigger 3          /*  
ST4...     /* Define trigger 4          /*  
ST5...     /* Define trigger 5          /*  
ST6...     /* Define trigger 6          /*  
S1         /* Start BM, enable SSC Mode /*  
SQ?        /* Query the trigger count  /*  
.....     /* Read the trigger count     /*  
.....     /* Wait a while                /*  
SQ?        /* Query the trigger count  /*  
.....     /* Read the trigger count     /*  
.....     /* Wait a while                /*  
S0         /* Halt the BM and disable SSC Mode /*  
SQ?        /* Query the final trigger count /*  
.....     /* Read the trigger count     /*
```

Now the trigger data can be read from the A24 memory at hex address \$200000.

12 WORKED EXAMPLES

EXAMPLE 1

Selectively trigger on the following commands with no post trigger count.

```
01 R 01 00
02 R 1F 1
03 T 01 01
1E T 02 10
08 R 00 00
00 R 00 00

ST1 0000100000100000,XXXXXXXXXXXXXXXXXX,0000
ST2 0001001111111111,XXXXXXXXXXXXXXXXXX,0000
ST3 0001110000100001,XXXXXXXXXXXXXXXXXX,0000
ST4 1110100010100000,XXXXXXXXXXXXXXXXXX,0000
ST5 0100000000000000,XXXXXXXXXXXXXXXXXX,0000
ST6 0000000000000000,XXXXXXXXXXXXXXXXXX,0000
S1          /* Start BM, enable SSC Mode          /*
SQ?         /* Query the trigger count             /*
.....      /* Read the trigger count              /*
.....      /* Wait a while                        /*
S0          /* Halt the BM and disable SSC Mode   /*
SQ?         /* Query the final trigger count      /*
.....      /* Read the trigger count              /*
```

Now the trigger data can be read from the A24 memory at hex address \$200000.

EXAMPLE 2

Selectively trigger on all bus traffic involving RT 01 with one post trigger word.

```
ST1 00001XXXXXXXXXX,XXXXXXXXXXXXXXXXXX,0001
ST2 0000000000000000,1XXXXXXXXXXXXXXXXXX,0001
ST3 0000000000000000,1XXXXXXXXXXXXXXXXXX,0001
ST4 0000000000000000,1XXXXXXXXXXXXXXXXXX,0001
ST5 0000000000000000,1XXXXXXXXXXXXXXXXXX,0001
ST6 0000000000000000,1XXXXXXXXXXXXXXXXXX,0001
S1          /* Start BM, enable SSC Mode          /*
SQ?         /* Query the trigger count             /*
.....      /* Read the trigger count              /*
.....      /* Wait a while                        /*
S0          /* Halt the BM and disable SSC Mode   /*
SQ?         /* Query the final trigger count      /*
.....      /* Read the trigger count              /*
```

Now the trigger data can be read from the A24 memory at hex address \$200000.

EXAMPLE 3

Selectively trigger on all parity errors.

```
ST1 00001XXXXXXXXXX,XXXXXXXXXXXXXXXX,0000
ST2 0000000000000000,XXXXXXXXXXXXXXXX,0000
ST3 0000000000000000,XXXXXXXXXXXXXXXX,0000
ST4 0000000000000000,XXXXXXXXXXXXXXXX,0000
ST5 0000000000000000,XXXXXXXXXXXXXXXX,0000
ST6 0000000000000000,XXXXXXXXXXXXXXXX,0000
S1      /* Start BM, enable SSC Mode      /*
SQ?     /* Query the trigger count        /*
.....  /* Read the trigger count         /*
.....  /* Wait a while                   /*
S0      /* Halt the BM and disable SSC Mode /*
SQ?     /* Query the final trigger count   /*
.....  /* Read the trigger count         /*
```

Now the trigger data can be read from the A24 memory at hex address \$200000.

APPENDIX E
1553 DATA BUS CONNECTIONS

13 1553 DATA BUS CONNECTIONS

Six 'triax' connectors (three for each bus) are provided on the front panel of SURETEST for connection to the 1553 bus.

The 1553 bus can be extended from the bus connector provided it is terminated correctly, enabling further stubs to be taken from the bus.

Figure E-1 shows the 1553 bus interfacing of the SURETEST 2704 board while figures E-2 through E-6 show different modes of connection for testing SURETEST 2704.

NOTE

**Connections are shown only for Primary Bus.
Secondary Bus is connected in the same manner.**

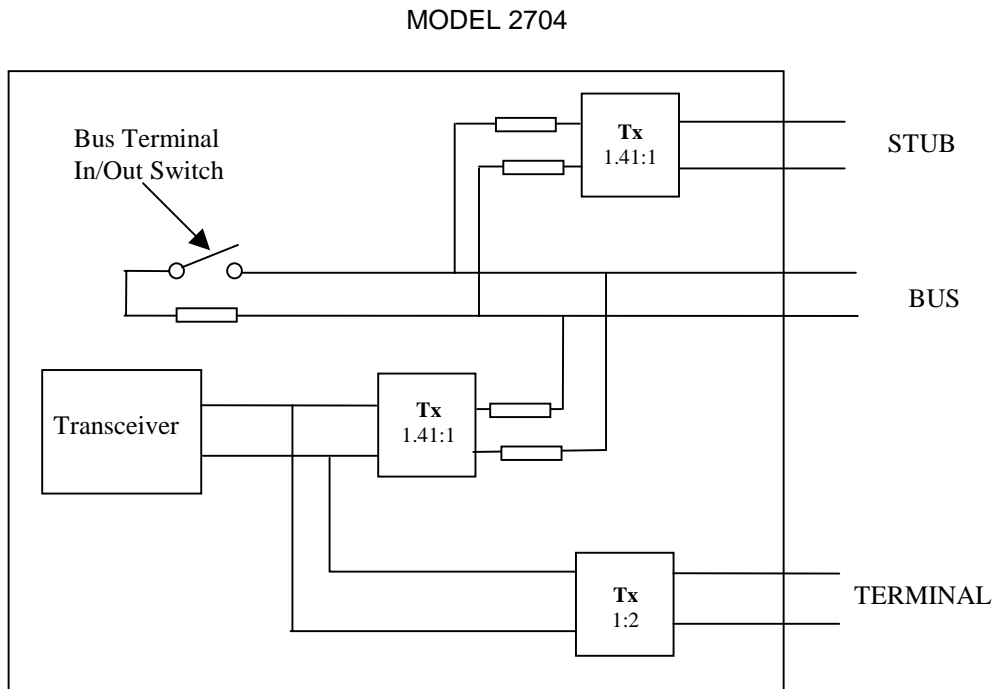

Figure 13-1 1553 Bus Interface

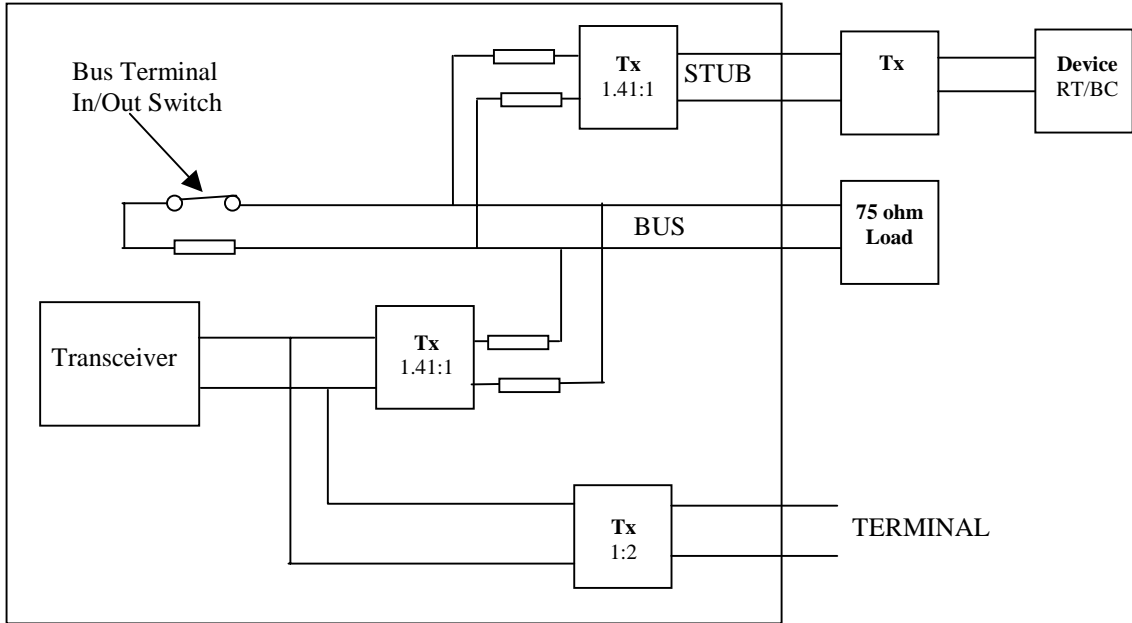

Figure 13-2 Bench testing Transformer Coupled Device
 (when no external 1553 bus is available)
 Bus Terminal Switch IN

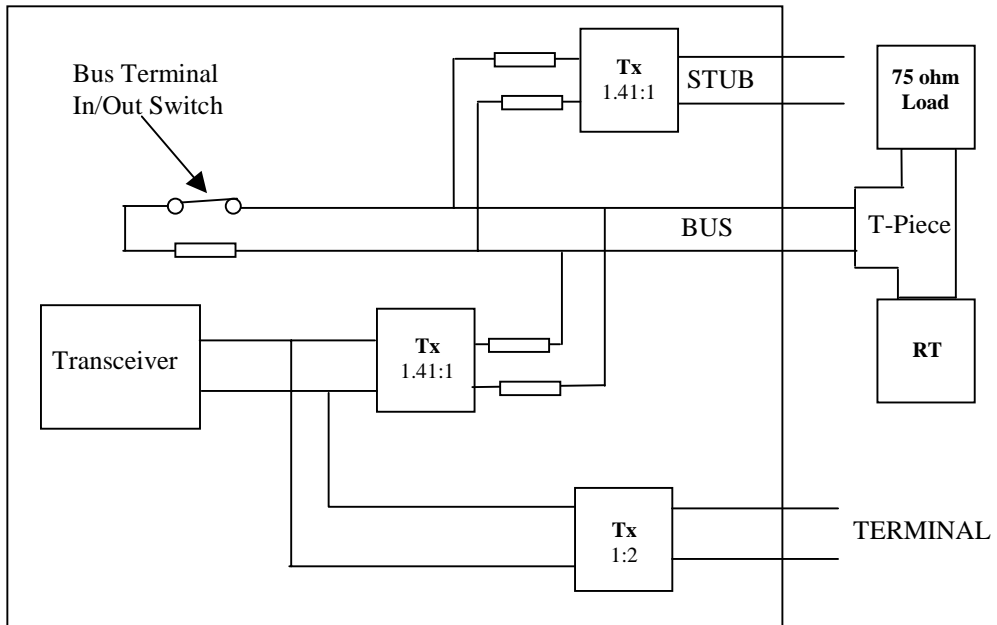

Figure 13-3 Bench testing Direct Coupled Stub on 1553 device
 Bus Terminal Switch IN

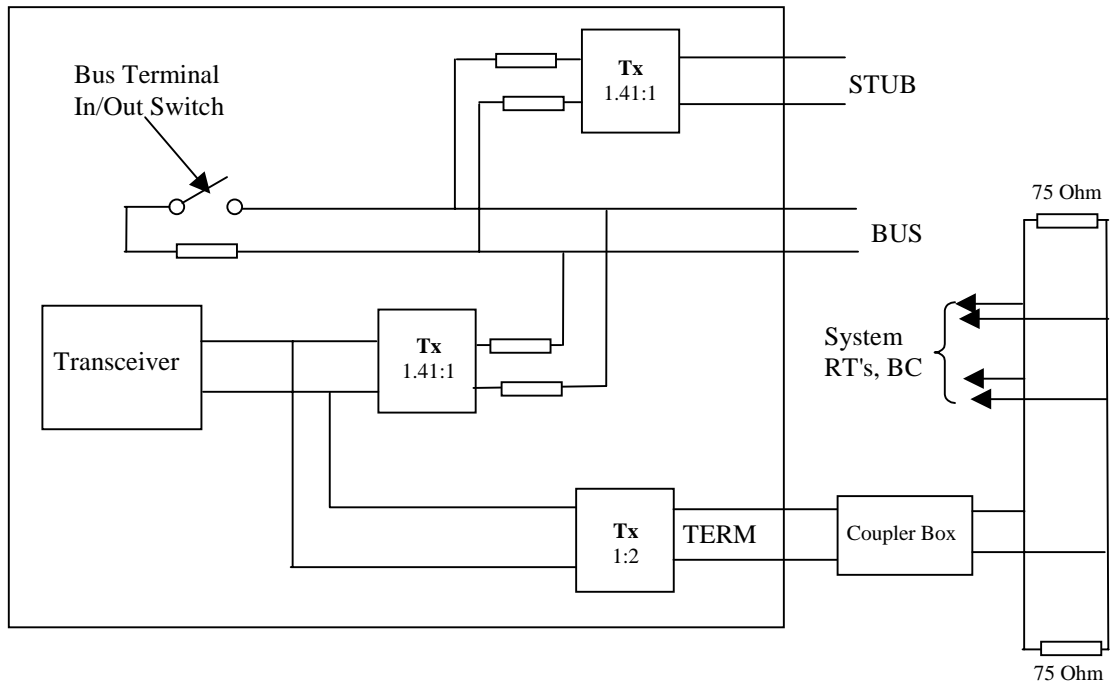

Figure 13-4 Replacement of RT/BC (but not the coupler box) in an existing system
 Bus Terminal Switch **OUT**

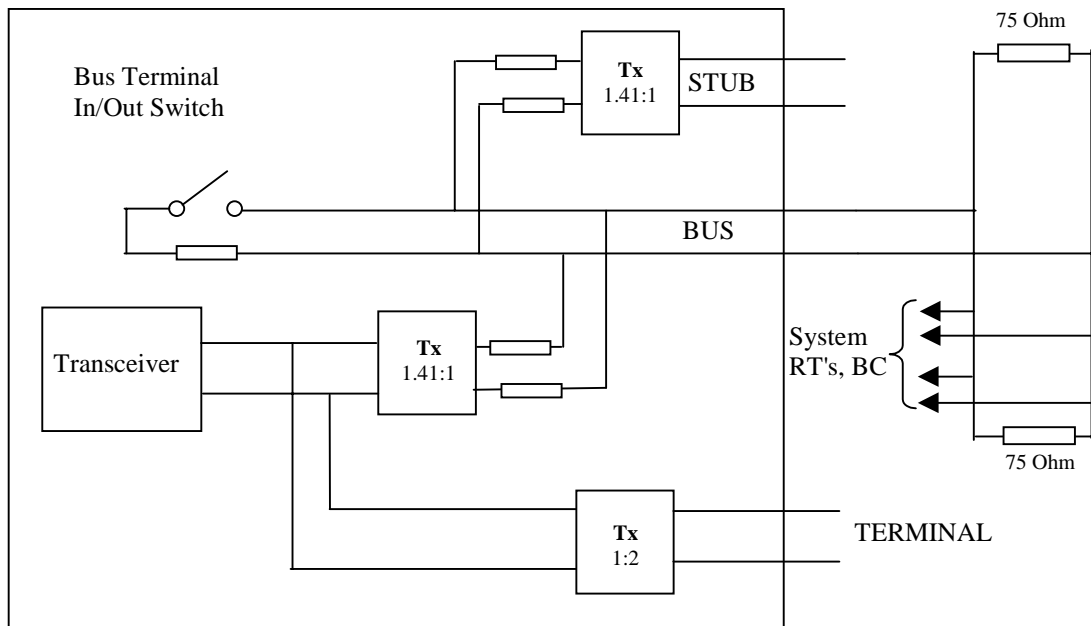
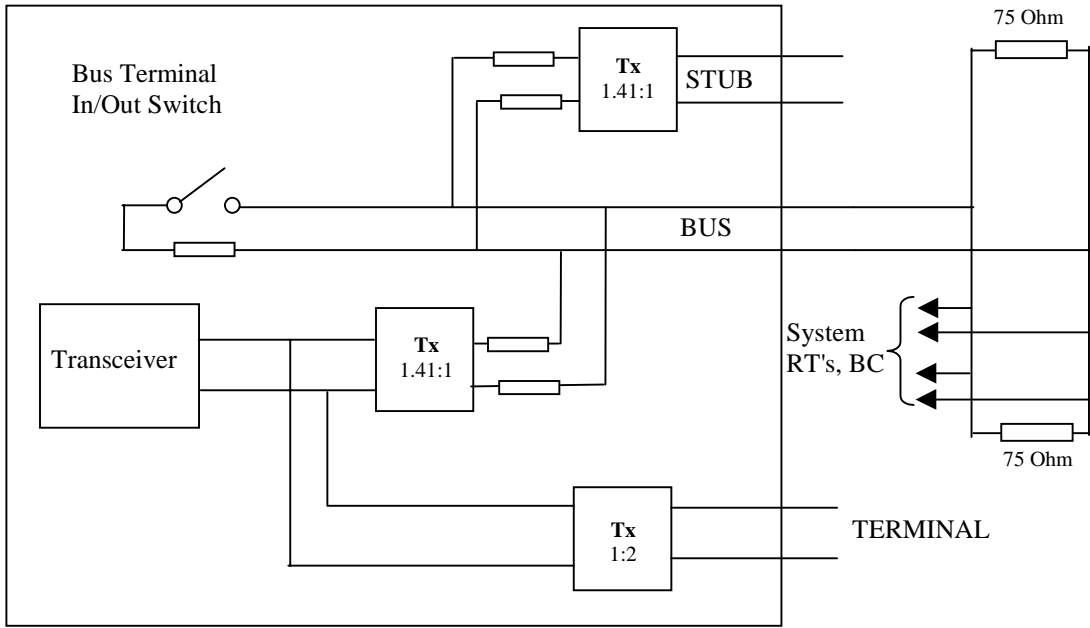

Figure 13-5 Replacement of RT/BC and coupler box in an existing system
 Bus Terminal Switch **OUT**



OR

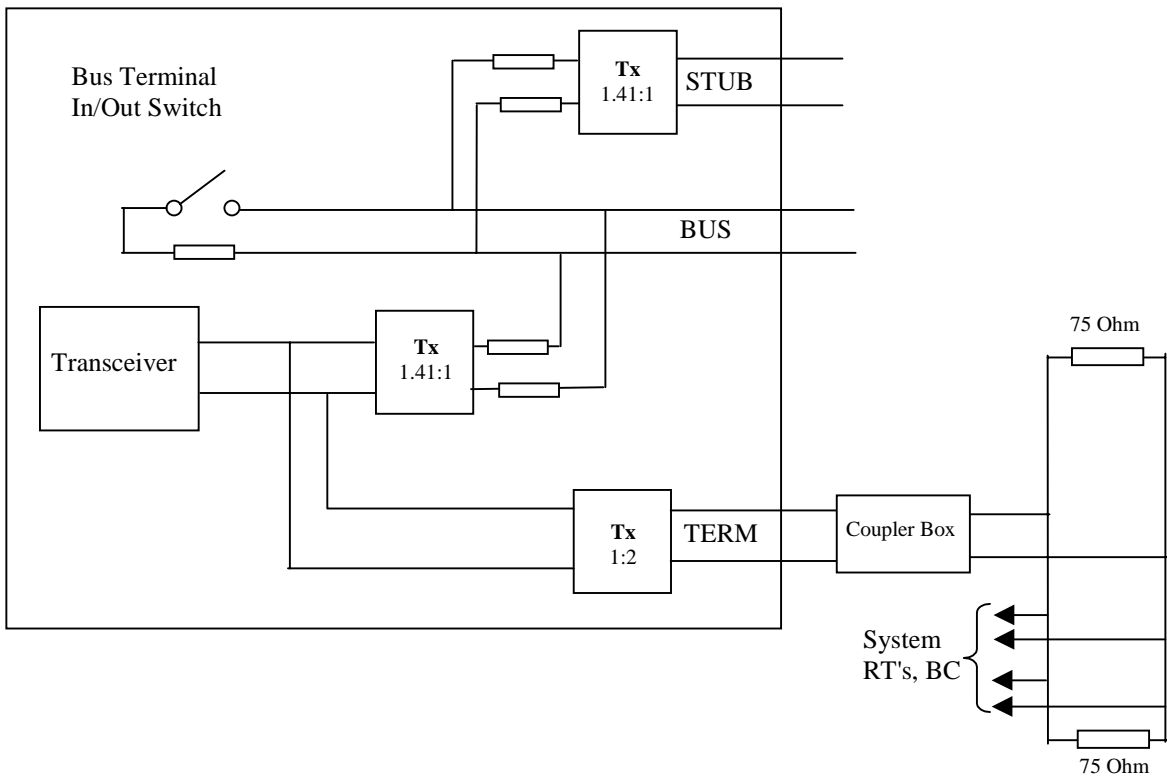

Figure 13-6 Monitoring of an External System

Bus Terminal Switch **OUT**

APPENDIX F
CONTROL INTERFACE INTERMEDIATE LANGUAGE (CIIL)

GENERAL INFORMATION

Section A

Section A contains definitions of the Control Interface Intermediate language (CIIL), including allowable mode designators, noun modifiers and operational codes. This section also defines data formats, message error masks, monitor trigger errors, gap times and response times.

Section B

Section B contains CIIL instructions that SURETEST is capable of receiving and transmitting. The syntax, structure and protocol of these instructions and responses is covered.

Section C

Section C contains examples on how the SURETEST can be programmed using CIIL. Examples are given on error bit positions, data formats, received messages, monitor triggers, external triggers and superseding commands.

14

CIIL DEFINITIONS AND SYNTAX

14.1 NOTATION KEY

< >	item definition or reference
::	<i>is defined to be</i>
[]	optional item or structure
{ }	set of choices or boundaries of a structure of inseparable items
:	exclusive OR
...	optional repetition

It should be noted that dimensional units which appear in the item definitions are for the purpose of identifying the standard units assumed on the CIIL bus; no dimensional unit designations are actually transmitted on the bus.

14.2 MODE DESIGNATORS, NOUN MODIFIERS AND OPERATIONAL (OP) CODES

The allowable *mode-designators* and *noun-modifiers*, and their ATLAS counterparts which may appear in transmissions to the SURETST are listed below:

Mode Designators:

CONL	CON-ONLY	EVMT	EVENT-MAX-TIME
COMO	CON-MON	EXCH	EXCHANGE
COSI	CON-SIM	GAPT	GAP-TIME
CSMO	CON-SIM-MON	GAWD	GATE-WIDTH
INTE	INTERFACE	GLMT	GAP-LIMIT
MONL	MON-ONLY	LLMT	LATE-RESP-LMT
SIMO	SIM-MON	MASK	MASK
SONL	SIM-ONLY	MAXT	MAX-TIME
TCON	TEST-EQUIP-CONTROL	MESG	MESSAGE
TMON	TEST-EQUIP-MONITOR	MSEM	MESSAGE-ERROR-MASK
TSIM	TEST-EQUIP-SIMULATE	MSGC	MESSAGE-COUNT
BEVA	BUS-EVENT-ANYTHING	NLMT	NO-RESP-LMT
BEVC	BUS-EVENT-COMMAND	POTW	POST-TRIGGER-WORDS
BEVD	BUS-EVENT-DATA	PROT	PROTOCOL
BEVE	BUS-EVENT-ERROR	RSPT	RESP-TIME
BEVS	BUS-EVENT-STATUS	SELM	SELECTIVE-MONITOR
BEVT	BUS-EVENT	SFRI	SUB-FRAME-INTERVAL
BUID	BUS-ID	STAT	STATUS
COMD	COMMAND	TRLV	TRIG-LEVEL
CRCC	CIRCULATE-CONTINUOUSLY	TRSC	TRIG-SOURCE
DAFB	DELAY-A-FROM-B	TRSL	TRIG-SLOPE
DATA	DATA	XMTL	TRANSMIT-LEVEL
DATC	DATA-COUNT		
DBFA	DELAY-B-FROM-A		

Operational Codes:

BGN	BEGIN DATA STRUCTURE
CLS	CLOSE
CNF	INTERNAL CONFIDENCE TEST
END	END DATA STRUCTURE
FNC	FUNCTION
FTH	FETCH
INX	INITIATE
IST	INTERNAL SELF-TEST
OPN	OPEN
RST	RESET
SBF	SUB-FUNCTION
SET	SETUP
STA	STATUS
GTL	GO TO LOCAL

Table 14-1 CIL Instructions

ITEM	DEFINITION
<bus-elect-setup>	:: <setup-clause>
<bus-test-setup>	:: FNC EXC <test-mode> : CH0 { <control-clause. <simulate-clause> <monitor-clause> } <eos> [RST EXC <test-mode> : CH0 <eos> [OPN : CH0 <eos>] [CLS : CH0 <eos>] [INX <test-mode> <eos>] [<fetch-clause>]
<u><setup-clause></u>	:: FNC EXC INTE : CH0 SET PROT T53B [SET XMTL <real-value> <volts-pp>] <eos>
<test-mode>	:: CONL : SONL : MONL: COSI : COMO : SIMO: CSMO
<real-value>	:: real number encodes as an ASCII a. integer or, b. decimal or, c. decimal in scientific notation.
<eos>	:: <cr> <lf>
<cr>	:: ASCII carriage return
<lf>	:: ASCII line-feed
<sp>	:: ASCII space

ITEM	DEFINITION
<u><control-clause></u>	<pre> :: SBF TCON [SET XTML <real-value> <volts-pp>] SET GAPT <real-value> <sec> <control-bus-id> [SET SFRI <real-value> <sec>] [SET CRCC] { BGN EXCH [<control-bus-id>] { BGN MSG { <control-command> [<bus-data>] } [<control-command> <bus-data>] END MSG [SET GAPT <real-value> <sec>] }... END EXCH }... </pre>
<control-bus-id>	<pre> :: SET BUID {AA : BB} : { SET BUID AB [SET DAFB <real-value> <sec> : SET DBFA <real-value> <sec>] } </pre>
<control-command>	<pre> :: SET COMD <hex-value-seven> [<hex-value-seven>] </pre>
<bus-data>	<pre> :: SET DATA <hex-value-seven>... </pre>
<hex-value-seven>	<pre> :: hexadecimal ASCII encoded integer consisting of 1-7 hexadecimal digits, right justified </pre>
<u><simulate-clause></u>	<pre> :: SBF TSIM [SET XTML <real-value> <volts-pp>] <simulate-bus-id> SET RSPT <real-value> <sec> { SET BEVT <hex-value-four> [<simulate-bus-id>] BGN EXCH BGN MSG { <bus-status> [<bus-data>] } END MSG END EXCH }... </pre>

ITEM		DEFINITION
<simulate-bus-id>	::	SET BUID {CO : OP : AB}
<bus-status>	::	SET STAT <hex-value-seven>
<hex-value-four>	::	hexadecimal ASCII encoded integer consisting of 1-4 hexadecimal digits, right justified
<u><monitor-clause></u>	::	SET TMON [SET POTW <int-value>] [SET LLMT <real-value> <sec>] [SET NLMT <real-value> <sec>] [SET GLMT <real-value> <sec>] [SET TRSC EXT SET TRLV <real-value> <volts> SET TRSL NEG SET MAXT <real-value> <sec>] { SET BEVD <hex-value-four>: SET BEVC <hex-value-four>: SET BEVS <hex-value-four>: SET BEVA <hex-value-four>: SET SELM <hex-value-four> [SET MASK <hex-value-four>] } [SET BEVE < hex-value-four >] SET EVMT <real-value> <sec> SET GAWD <real-value> <sec>
<u><fetch-clause></u>	::	FTH <bus-info> <eos>
<bus-info>	::	MSGC : <info-id> <message-number>
<info-id>	::	{ BUID : MSEM : COMD : GAPT : RSPT : STAT : DATA : DATC }
<message-number>	::	<int-value>
<int-value>	::	ASCII encoded integer

14.3 DATA FORMATS

Implied data formats are used for the command, status, and data words comprising the messages sent to and received from the SURETEST. The data is formatted as a 28 bit, right-justified data item, without leading zeros. The format of the data item is as follows:

Bits 0-3:

The bit position at which an invalid Manchester encoding is to be inserted. This number refers to the data portion of the 1553 word only (not the sync. or parity positions), and must be 7 implying data #8.

Bits 4-11:

Error mask describing the errors to be inserted in the word, or those detected by the SURETEST monitor. The format of the MASK is as follows (Bit 0 is the Most Significant Bit (MSB)):

Bit	4:	Parity	(0-OK, 1-bad)	*
Bit	5:	Bit Count	(0-OK, 1-low)	*
Bit	6:	Bit Count	(0-OK, 1-high)	*
Bit	7:	Sync.	(0-OK, 1-inverted)	*
Bit	8:		(0-always)	
Bit	9:	Manchester	(0-OK, 1-insert error)	*
Bit	10:	Simultaneous Traffic	(0-no, 1-yes)	*
Bit	11:	Invalid Word	(0-no, 1-yes)	**

Bit 11 is for parity and/or bit count and is therefore the logical OR of bits 4, 5 and 6.

* Insert and report
** Report only

Bits 12-27:

A normal MIL-STD-1553 data bit pattern.

14.4 MESSAGE-ERROR-MASK

Message-level errors will be retrieved using the modifier MESSAGE-ERROR-MASK (CIIL abbreviation, MSEM). This modifier will be associated with a 16 bit data item, whose implied format is as follows:

Bit	0:	Inter-message Gap	(0-OK, 1-high)
Bit	1:	Inter-message Gap	(0-OK, 1-low)
Bit	2:	Response Bus	(0-OK, 1-opposite)
Bit	3:	Response Time	(0-OK, 1-no-response)
Bit	4:	Response Time	(0-OK, 1-early)
Bit	5:	Response Time	(0-OK, 1-late)
Bit	6:	Word Count	(0-OK, 1-high)
Bit	7:	Word Count	(0-OK, 1-low)

14.5 MONITOR TRIGGER ERRORS

Monitor will trigger on error as defined by modifier Bus-Event-Error (CIIL abbreviation BEVE). This modifier will be associated with a 16 bit data item, whose implied format is as follows:

1 = trigger if error present. 0=don't trigger on this error.

Bit	0-5:	spare
Bit	6:	Terminal Address
Bit	7:	No response
Bit	8:	Slow response
Bit	9:	Both buses
Bit	10:	Wrong bus
Bit	11:	Word count
Bit	12:	Manchester
Bit	13:	Word Length Long
Bit	14:	Word Length Short
Bit	15:	parity

14.6 GAP TIME

Gap Time will be reported by SURETEST as a <real-value> in seconds.

14.7 RESPONSE TIME

Response Time will be reported by the SURETEST as a <real-value> in seconds, if there is only one Response Time for that message, or <real-value> <sp> <real-value> if there are two response times for the request message.

15

SURETEST CIIL INSTRUCTIONS

15.1 INTRODUCTION

The CIIL bus language defined herein is a subset of MATE-STD-2806763, plus SURETEST peculiar language, which has been submitted for approval.

NOTE

In the event of conflict between this section and section S1 and/or the MATE System Control Interface Standard, MATE-STD-2806763, Section S1 and MATE-STD-2806763 take precedence.

All MATE CIIL instructions, transmitted by the MATE host computer to the SURETEST will appear as American Standard Code for Information Interchange (ASCII) text. The allowable character set will be limited to upper case alphas, numeric, ., :, +, -, <SP>, **CR**, and **LF**. All hexadecimal values will be represented as ASCII encoded hex (0-9, A-F). All integer values will be transmitted as ASCII numerics. All instruction words will be separated by a <SP>. All transmissions will be terminated by a carriage return and line feed. <**cr**, **lf**>.

Each transmission will be limited to 8,000 characters in length. Each character will appear as binary encoded ASCII with the most significant bit set to logic 0.

Should the SURETEST detect any syntactical errors in a transmission, the entire transmission will be ignored, and an error response will be queued for reporting to the MATE host computer.

15.2 SYNTAX

The tables on the following pages define the allowable syntax for each MATE CIIL instruction to be interpreted by the SURETEST. A CIIL instruction is defined as having an opcode *VERB*, followed by up to three types of operands. The operands appear as a *NOUN*, a *value*, in that order. Depending upon the specific opcode, the appearance of a given operand may, or may not, be required; as defined in the tables below. The *Context* column in the tables below define the allowable context for each CIIL instruction. The *Default* column defines the default action taken in the absence of a specific (operand dependant) CIIL instruction in each allowable context. The *Comments* column defines the units, or meaning of the *value* operand, for the specific CIIL instruction. The *Comments* column also refers to the NOTES pertaining to unique syntactical requirements for the specific CIIL instruction.

The KEY to the syntax tables (15-1 and 15-2) is as follows:

KEY:

---or----	indicates no operand required or expected.
i	indicates a decimal value in unsigned integer notation with no embedded blanks
xxxxxxx	indicates up to 7 hex character field (right justified)
y	indicates a decimal value in either unsigned integer notation, or signed scientific notation, with no embedded blanks. (sign may be +, or -, no sign indicates plus).
z	indicates up to 4 hex character field (right justified)

Table 15-1 Syntax

VERB	NOUN	MDFYR	Value	Context	Default	Comments
FNC	EXC	CONL SONL MONL COSI COMO SIMO CSMO INTE	:CH0	ANY	None	Note 1
OPN	---	----	:CH0	ANY	None	
CLS	---	----	:CH0	ANY	None	
INX	---	CONL SONL MONL COSI COMO SIMO CSMO	----	ANY	None	Note 2
FTH	---	COMD DATA STAT MSEM BUID DATC GAPT RSPT MSGC	y y y y y y y y ----	ANY	None	Note 3
RST	EXC	CONL SONL MONL COSI COMO SIMO CSMO	:CH0	ANY	None	
CNF	---	----	----	ANY	None	
IST	---	----	----	ANY	None	
STA	---	----	----	ANY	None	

NOTE

With the exception of **FNC**, these instructions each appear in their own transmission, terminated with **CR, LF**.

FNC also appears in a unique transmission, terminated with **CR LF**; however, other instructions (**SBF, BGN, END, SET**) may also appear within the same transmission following the **FNC** instruction.

Table 15-1 Syntax (Continued)

VERB	NOUN	MDFYR	Value	Context	Default	Comments
SBF	---	TCON TMON TSIM	----	:FNC EXC	None	Note 4
BGN	---	MESG	----	TCOM TSIM	None	
		EXCH			None	
END	---	MESG	----	TCON TSIM	None	
		EXCH			None	

None of these instructions may appear in its own transmission.

The mnemonics listed in the *Context* column refer to the **FNC EXC** instruction, or the *MDFYR* of the **SBF** instruction which specifies the setup clause in whose context the instruction is permissible (see Note 4)

Table 15-2 Syntax - Set Code

VERB	NOUN	MDFYR	Value	Context	Default	Comments
SET	---	BEVT	zzzz	TSIM	None, Error	
		BEVC	zzzz	TMON	None, Error	Note 5
		BEVD	zzzz	TMON	None, Error	Note 5
		BEVS	zzzz	TMON	None, Error	Note 5
		BEVA	zzzz	TMON	None, Error	Note 5
		BUID	AB	TCON or TSIM	None, Error	Notes 6 & 9
			AA	TCON	None, Error	
			BB	TCON	None, Error	
			CO	TSIM	None, Error	
			OP	TSIM	None, Error	
		COMD	xxxxxxx	TCON	None, Error	Notes 7 & 9

Table 15-2 Syntax - Set Code (Continued)

VERB	NOUN	MDFYR	Value	Context	Default	Comments
	CRCC	---	TCON	Frame Halt		
		DAFB	y	TCON	No Delay	Note 6
		DATA	xxxxxxx	TCON or TSIM	No Data	Note 8
		DBFA	y	TCON	No Delay	Note 6
SET	---	EVMT	y	TMON	None, Error	
		GAPT	y	TCON	None, Error	Note 10
		GAWD	y	TMON	None, Error	
		GLMT	y	TMON	32,767 uSec	
		LLMT	y	TMON	12 uSec	
		MASK	zzzz	TMON	No Mask	
		MAXT	y	TMON	None, Error	
		NLMT	y	TMON	14 uSec	
		POTW	y	TMON	10,000	
		PROT	T53B	FNC EXC	None, Error	Note 4
		RSPT	y	TSIM	None, Error	Note 11
		SELM	zzzz	TMON	None, Error	
		SFRI	y	TCON	None, Error	
SET	---	STAT	xxxxxxx	TSIM	None, Error	Note 12
		TRLV	y	TMON	None, Error	
		TRSC	EXT	TMON	No Ext Trig	
		TRSL	NEG	TMON	None, Error	
		XMTL	y	FNC EXC or TCON or TSIM	0 volts	Note 4

None of these instructions may appear in its own transmission.

The mnemonics listed in the *Context* column refer to the **FNC EXC** instruction, or the *MDFYR* of the **SBF** instruction which specifies the setup clause in whose context the instruction is permissible (see Note 4)

NOTES for SYNTAX TABLES 15-1 and 15-2

- Note 1** The **FNC EXC....** instruction explicitly opens the specified setup clauses. The *MDFYR* of the instruction specifies the setup clauses as configuring the Bus Controller only **CONL**, the RT Simulators only **SONL**, the Bus Monitor only **MONL**, the Bus Controller Simulator and RT Simulators **COSI**, the Bus Controller Simulator and Bus Monitor **COMO**, the RT Simulators and Bus Monitor **SIMO**, or the Bus Controller Simulator and RT Simulators and Bus Monitor **CSMO**. The electrical/protocol characteristics of the SURETEST are redefined in each **FNC EXC....** transmission.
- Note 2** The *MDFYR* for the **INX** verb must match the combination of modes previously setup by the **FNC EXC....** transmission which have not been reset by **RST EXC...** transmission canceling any elements(s) of that combination.
- Note 3** The **FTH...** transmission must have been preceded by the setup of the Monitor mode (**FNC EXC MONL**, **FNC EXC COMO**, **FNC EXC SIMO**, or **FNC EXC CSMO**), and the initiation of the Monitor mode (with the appropriate **INX....** instruction). If an external trigger qualifier or sync input has been selected (**SET TRSC EXT**) this instruction may or may not precede the occurrence of the external trigger qualifier itself.
- Note 4** The **SET PROT** instruction must appear before the first **SBF** instruction in any transmission. The **SET XMTL** instruction may appear in:
- The **EXT INTE** structure, to define output voltage of both controller and RT simulators.
 - The **TCON** structure to define the output voltage of the controller.
 - The **TSIM** structure to define the output voltage of the RT simulators.
- The *MDFYR* of the **SBF** instruction defines the context for all subsequent **SET**, **BGN**, and **END** instructions until the appearance of another **SBF** instruction, or **CR LF**.
- The *MDFYR* of the **FNC EXC** instruction defines the combination *MDFYRs* to **SBF** instructions that will appear in the transmissions.
- Note 5** In the **TMON** context, the five *MDFYRs* (**BEVE**, **BEVS**, **BEVC**, **BEVD**, **BEVA**) are mutually exclusive. In the **TSIM** context, the **SET BEVT** instruction must appear once before each **BGN MMSG** instruction.
- Note 6** The **SET BUID** instruction must appear once prior to the first **BGN EXCH** instruction in both the **TCON**, and **TSIM** context. The **SET BUID** instruction may appear once before any subsequent **BGN MMSG** instruction in either the **TCON**, or **TSIM** context. In the **TCON** context, the appearance of the command **SET BUID AB** permits the appearance of the **SET DAFB y** or **SET DBFA y** instruction immediately following the **SET BUID AB** instruction. This is the only syntax in which the **SET DAFB** or **SET DBFA** instruction may appear.
- Note 7** The **SET COMD xxxx** instruction may appear with up to 2 value fields. This instruction must appear within each **BGN MMSG / END MMSG** structure, and may appear up to two times within each structure. The second occurrence is the command that supports the first occurrence.
- Note 8** The **SET DATA xxxx** instruction may appear with up to 33 value fields within any **BGN MMSG / END MMSG** structure. Any such instruction may appear one additional time with up to 33 value fields if a second **SET COMD** was used for superseding commands. If the **SET COMD** instruction contained 2 value fields, then it cannot be followed by a **SET DATA xxxx** instruction.

Note 9 If the **SET BUID AB** instruction appears and only one **SET COMD xxxx** instruction appears in the same **BGN MMSG / END MMSG** structure then the superseding command will be the same as the first command. If the first and superseding commands are different, then a time delay between the commands must have been specified by the **SET DAFB y** or **SET DBFA y**.

Note 10 The **SET GAPT y** instruction must appear once before the first **BGN EXCH** instruction in the **TCON** context. The **SET GAPT** instruction may appear immediately following any subsequent **END MMSG** instruction

Note 11 The **SET RSPT y** instruction must appear once before the first **BGN EXCH** instruction in the **TSIM** context.

Note 12 The **SET STAT xxxx** instruction must appear with only 1 value field within each **BGN MMSG / END MMSG** structure in the **TSIM** context.

The MATE CIIL instructions transmitted by the MATE host computer to the SURETEST, defined syntactically above are each described. SURETEST actions/responses to each command are also defined.

15.3 INPUT COMMANDS TO THE SURETEST

CNF This instruction directs the SURETEST to exit whatever operating or setup mode the SURETEST happens to be in, and to initiate Confidence Testing.

IST This instruction directs the SURETEST to exit whatever operating or setup mode the SURETEST happens to be in, and to initiate Built-in-Test.

STA This instruction directs the SURETEST to report its current status.

OPN This instruction directs the SURETEST to deactivate its bus interfaces.

CLS This instruction directs the SURETEST to activate its bus interfaces.

FTH MSGC This instruction directs the SURETEST to report the number of complete 1553 messages which have been stored in the Monitor from the occurrence of the Monitor Trigger condition to the time-out of the Gate Width timer. The message in which the trigger condition occurred is considered message number 1. The absence of a trigger condition within the time specified by the **SET EVMT y** instruction will result in the reporting of a 1553 bus error condition.

FTH BUID y This instruction directs the SURETEST to report the **BUS ID** over which the words of message number **y** was received. The absence of message number **y** will result in the reporting of 1553 error condition. The absence of a trigger condition within the time specified by the **SET EVMT y** instruction will result in the reporting of a 1553 bus error condition.

FTH MSEM y This instruction directs the SURETEST to report any message level errors detected for message number **y** formulated in accordance with the **MESSAGE-ERROR-MASK** defined in Section 15. The absence of message number **y** will result in the reporting of a 1553 error condition. The absence of a trigger condition within the time specified by the **SET EVMT y** instruction will result in the reporting of a 1553 bus error condition.

FTH COMD y	This instruction directs the SURETEST to report all 1553 command words associated with message number y . The absence of message number y will result in the reporting of a 1553 error condition. The absence of a trigger condition within the time specified by the SET EVMT y instruction will result in the reporting of a 1553 bus error condition. The absence of any command words in message number y will result in the reporting of a zero bus command. Each command word will be reported with associated word level error appended as specified by implied data format defined in Section 15.
FTH DATA y	This instruction directs the SURETEST to report all 1553 data words associated with message number y . The absence of message number y will result in the reporting of a 1553 error condition. The absence of a trigger condition within the time specified by the SET EVMT y instruction will result in the reporting of a 1553 bus error condition. The absence of any data words in message number y will result in the reporting of a zero bus data word. Each data word will be reported with associated word level error appended as specified by implied data format defined in Section 15.
FTH STAT y	This instruction directs the SURETEST to report all 1553 status words associated with message number y . The absence of message number y will result in the reporting of a 1553 error condition. The absence of a trigger condition within the time specified by the SET EVMT y instruction will result in the reporting of a 1553 bus error condition. The absence of any status words in message number y will result in the reporting of a zero status response word. Each status word will be reported with associated word level error appended as specified by implied data format defined in Section 15.
FTH DATC y	This instruction directs the SURETEST to report all 1553 status words associated with message number y . The absence of message number y will result in the reporting of a 1553 error condition. The absence of a trigger condition within the time specified by the SET EVMT y instruction will result in the reporting of a 1553 bus error condition.
FTH GAPT y	This instruction directs the SURETEST to report the Gap Time of message number y . The absence of message number y will result in the reporting of a 1553 error condition. The absence of a trigger condition within the time specified by the SET EVMT y instruction will result in the reporting of a 1553 bus error condition.
FTH RSPT y	This instruction directs the SURETEST to report the Response Time of message number y . The absence of message number y will result in the reporting of a 1553 error condition. The absence of a trigger condition within the time specified by the SET EVMT y instruction will result in the reporting of a 1553 bus error condition.
INX CONL	This instruction directs the SURETEST to initiate the Bus Controller Simulator using the configuration parameters defined by the preceding configuration clause. The Bus Controller Simulator mode must have been previously configured and not cancelled by a RST EXC CONL : CH0 , RST EXC COSI : CH0 , RST EXC COMO : CH0 , or RST EXC CSMO :CH0 instruction. SURETEST must reply with a Status Normal response.
INX SONL	This instruction directs the SURETEST to initiate the RT Simulator using the configuration parameters defined by the preceding configuration clause. The RT Simulator mode must have been previously configured and not cancelled by a RST EXC SONL : CH0 , RST EXC COSI : CH0 , RST EXC SIMO : CH0 , or RST EXC CSMO :CH0 instruction. SURETEST must reply with a Status Normal response.

INX MONL	This instruction directs the SURETEST to initiate the Bus Monitor using the configuration parameters defined by the preceding configuration clause. The Bus Monitor mode must have been previously configured and not cancelled by a RST EXC MONL : CH0, RST EXC COMO : CH0, RST EXC SIMO : CH0, or RST EXC CSMO :CH0 instruction. SURETEST must respond with a time value indicating the total time the MATE host computer should wait for a response to a FTH... instruction.
INX COSI	This instruction directs the SURETEST to initiate the Bus Controller Simulator and RT Simulator using the configuration parameters defined by the preceding configuration clauses. The Bus Controller Simulator and RT Simulator modes must have been previously configured and not cancelled by a RST EXC COSI : CH0, RST EXC CONL : CH0, RST EXC SONL : CH0, RST EXC COMO : CH0, RST EXC SIMO : CH0, or RST EXC CSMO :CH0 instruction. SURETEST must reply with a Status Normal response.
INX COMO	This instruction directs the SURETEST to initiate the Bus Controller Simulator and Bus Monitor using the configuration parameters defined by the preceding configuration clauses. The Bus Controller Simulator and Bus Monitor modes must have been previously configured and not cancelled by a RST EXC COMO : CH0, RST EXC CONL : CH0, RST EXC MONL : CH0, RST EXC COSI : CH0, RST EXC SIMO : CH0, or RST EXC CSMO :CH0 instruction. . SURETEST must respond with a time value indicating the total time the MATE host computer should wait for a response to a FTH... instruction.
INX SIMO	This instruction directs the SURETEST to initiate the RT Simulator and Bus Monitor using the configuration parameters defined by the preceding configuration clauses. The RT Simulator and Bus Monitor modes must have been previously configured and not cancelled by a RST EXC SIMO : CH0, RST EXC SONL : CH0, RST EXC MONL : CH0, RST EXC COSI : CH0, RST EXC COMO : CH0, or RST EXC CSMO :CH0 instruction. . SURETEST must respond with a time value indicating the total time the MATE host computer should wait for a response to a FTH... instruction.
INX CSMO	This instruction directs the SURETEST to initiate the Bus Controller Simulator, RT Simulator and Bus Monitor using the configuration parameters defined by the preceding configuration clauses. The Bus Controller Simulator, RT Simulator and Bus Monitor modes must have been previously configured and not cancelled by a RST EXC CSMO : CH0, RST EXC CONL : CH0, RST EXC SONL : CH0, RST EXC MONL : CH0, RST EXC SIMO : CH0, , RST EXC COSI : CH0, or RST EXC COMO :CH0 instruction. . SURETEST must respond with a time value indicating the total time the MATE host computer should wait for a response to a FTH... instruction.
RST EXC CONL :CH0	This instruction directs the SURETEST to disable the BC Simulator, and return all BC Simulator configuration parameters to their default values.
RST EXC SONL :CH0	This instruction directs the SURETEST to disable the RT Simulator, and return all RT Simulator configuration parameters to their default values.

RST EXC MONL :CH0	This instruction directs the SURETEST to disable the Bus monitor, and return all Bus monitor configuration parameters to their default values.
RST EXC COSI :CH0	This instruction directs the SURETEST to disable the BC Simulator and RT Simulator, and return all BC Simulator and RT Simulator configuration parameters to their default values.
RST EXC COMO :CH0	This instruction directs the SURETEST to disable the BC Simulator and Bus Monitor, and return all BC Simulator and Bus Monitor configuration parameters to their default values.
RST EXC SIMO :CH0	This instruction directs the SURETEST to disable the RT Simulator, and Bus Monitor, and return all RT Simulator and Bus Monitor configuration parameters to their default values.
RST EXC CSMO :CH0	This instruction directs the SURETEST to disable the BC Simulator, RT Simulator and Bus Monitor, and return all BC Simulator, RT Simulator and Bus Monitor configuration parameters to their default values.
FNC EXC CONL : CH0	This instruction directs the SURETEST to accept each subsequent SET instruction in the context of defining the set up of the SURETEST electrical and protocol parameters. This instruction also defines the sub-function to be configured in this transmission to be limited to the BC TCON .
FNC EXC SONL : CH0	This instruction directs the SURETEST to accept each subsequent SET instruction in the context of defining the set up of the SURETEST electrical and protocol parameters. This instruction also defines the sub-function to be configured in this transmission to be limited to the RT Simulator TSIM .
FNC EXC MONI : CH0	This instruction directs the SURETEST to accept each subsequent SET instruction in the context of defining the set up of the SURETEST electrical and protocol parameters. This instruction to be limited to the Bus Monitor TMON .
FNC EXC COSI : CH0	This instruction directs the SURETEST to accept each subsequent SET instruction in the context of defining the set up of the SURETEST electrical and protocol parameters. This instruction also defines the sub-function to be configured in this transmission to be limited to the BC TCON and the RT Simulator TSIM .
FNC EXC COMO : CH0	This instruction directs the SURETEST to accept each subsequent SET instruction in the context of defining the set up of the SURETEST electrical and protocol parameters. This instruction also defines the sub-function to be configured in this transmission to be limited to the BC TCON and the Bus monitor TMON .
FNC EXC SIMO : CH0	This instruction directs the SURETEST to accept each subsequent SET instruction in the context of defining the set up of the SURETEST electrical and protocol parameters. This instruction also defines the sub-function to be configured in this transmission to be limited to the RT Simulator TSIM and the Bus monitor TMON .
FNC EXC INTE : CH0	This instruction directs the SURETEST to accept electrical setup parameters. i.e., set PROT and set XMTL .

SBF TCON	This instruction directs the SURETEST to accept each subsequent SET or BGN or END instruction in the context of defining the configuration parameters of the SURETEST BC Simulator.
SBF TMON	This instruction directs the SURETEST to accept each subsequent SET or BGN or END instruction in the context of defining the configuration parameters of the SURETEST RT Simulator(s).
SET PROT xxxx	This instruction directs the SURETEST to select the 1553 protocol for the Bus Monitor, BC Simulator, and RT Simulator according to the contents of the value field xxxx .
SET XMTL y	This instruction directs the SURETEST to define the output amplitude for all messages transmitted by the SURETEST to be that contained in the value field y . The definition of an amplitude less than 0 Vp-p, or greater than 20 Vp-p, will constitute an error.
SET EVMT y	This instruction directs the SURETEST to define the duration of its internal watchdog timer to be that contained in the value field y . The timer will be started upon receipt of a trigger qualification on INX MONL , INX COMO , INX SIMO , or INX CSMO instruction. Should the defined 1553 bus trigger condition not occur prior to the time-out of the watchdog, an error response will be queued for reporting to the MATE host computer. The definition of a time value less than 120 uSec, or greater than 30 Sec will constitute an error. The resolution of the Gate Width is +/- 5 uSec
SET GAWD y	This instruction directs the SURETEST to define the duration of its internal gate width timer to be that contained in the value field y . The timer will be started upon receipt of the bus monitor trigger event. When the gate width time is complete, the SURETEST will disable the 1553 bus monitor to halt the capture of 1553 data. The definition of a time value less than 120 uSec, or greater than 30 Sec will constitute an error. The resolution of the Gate Width is +/- 5 uSec
SET TRLV y	This instruction directs the SURETEST to define the voltage threshold for the external trigger qualifier input to be contained in the value field y . The definition of a threshold of less than 0 Volts, or greater than 0.4 Volts, will constitute an error.
SET TRSC EXT	This instruction directs the SURETEST to select the external trigger qualifier mode. The defined trigger condition is qualified upon the receipt of the INX MONL , INX COMO , INX SIMO , or INX CSMO instruction and the occurrence of the external trigger qualifier input.
SET TRSL xxx	This instruction directs the SURETEST to define the slope for the external trigger qualifier input to be that contained in the value field xxx . The definition of a slope other than negative will constitute an error.
SET BEVC zzzz	This instruction directs the SURETEST to select the Bus Monitor data retention trigger source as a command word.
SET BEVD zzzz	This instruction directs the SURETEST to select the Bus Monitor data retention trigger source as a data word of the specified pattern.
SET BEVS zzzz	This instruction directs the SURETEST to select the Bus Monitor data retention trigger source as a status word of the specified pattern.

SET BEVA zzzz	This instruction directs the SURETEST to select the Bus Monitor data retention trigger source as any word of the specified pattern.
SET MASK zzzz	This instruction directs the SURETEST to apply the contents of the value field zzzz as a mask to the value defined in the SET BEVC zzzz , SET BEVD zzzz , SET BEVS zzzz , SET BEVA zzzz or SET SELM zzzz in the monitor clause.
SET BEVE zzzz	This instruction directs the SURETEST to select the Bus Monitor data retention trigger source as an error condition within the word type defined by the SET BEVC zzzz , SET BEVD zzzz , SET BEVS zzzz , SET BEVA zzzz or SET SELM zzzz instruction.
SET GLMT y	This instruction directs the SURETEST to define the Bus Monitor intermessage gap time limit to be that contained in the value field y . The definition of a time value of less than 2 uSec, or greater than 65,279 uSec, will constitute an error.
SET LLMT y	This instruction directs the SURETEST to define the Bus Monitor RT late response time limit to be that contained in the value field y . The definition of a time value of less than 2 uSec, or greater than 100 uSec, will constitute an error.
SET NLMT y	This instruction directs the SURETEST to define the Bus Monitor RT no response time limit to be that contained in the value field y . The definition of a time value of less than 14 uSec, or greater than 59,999 uSec, will constitute an error.
BGN MMSG	This instruction directs the SURETEST to accept all subsequent SET... instructions until the receipt of an END MMSG instruction as defining the contents of a specific message for either the BC simulator, or the RT simulator.
BGN EXCH	In the BC simulator configuration context, this instruction directs the SURETEST to accept all subsequent SET... instructions and BGN/END MSG structures until the receipt of an END EXCH instruction as defining a specific subframe. In the RT simulator configuration context, the instruction directs the SURETEST to accept all subsequent SET... instructions and BGN/END MSG structures until the receipt of an END EXCH instruction as defining a specific RT response.
END MMSG	This instruction directs the SURETEST to complete the definition of the contents of a specific message for either the BC simulator, or the RT simulator.
END EXCH	In the BC simulator configuration context, this instruction directs the SURETEST to complete the definition of the specific subframe. In the RT simulator configuration context, the instruction directs the SURETEST to complete the definition of the specific RT response.
SET BUID xx	In the BC simulator configuration context, this instruction directs the SURETEST to select the bus defined in the value field xx as the default bus for transmission of all messages subsequently defined for the BC simulator. Should this instruction appear immediately prior to definition for a specific message, the bus defined by the field value xx is selected for the transmission of that specific message.

In the RT simulator configuration context, this instruction directs the SURETEST to select the bus defined in the value field **xx** as the default bus for the transmission of all responses defined for the RT simulator. . Should this instruction appear within the definition of a RT response, the bus defined by the field value **xx** is selected for the transmission of that response.

- SET DATA xxxxxxxx** This instruction directs the SURETEST to define the contents of the 1553 data word(s) to be transmitted, to be that contained in the least significant four hex digits of each of the value field(s) **xxxxxxx**. The most significant three hex digits of each of the value field(s) define the word level error pattern to be injected in the transmission of each data word.
- SET SFRI y** This instruction directs the SURETEST to define the subframe transmission interval for the BC simulator to be defined in the value field **y**. The definition of a time value of less than 10 uSec, or greater than 30 Sec, will constitute an error.
- SET CRCC** This instruction directs the SURETEST to transmit the set of BC simulator messages defined in subframes at setup, continuously as a sequence of major frames. The absence of this instruction in the configuration of the BC simulator implies the transmission of the defined subframes as a one-shot frame.
- SET COMD xxxxxxxx** This instruction directs the SURETEST to define the contents of the command word(s) to be transmitted, to be that contained in the least significant four hex digits of each of the value field(s) **xxxxxxx**. The most significant three hex digits of each of the value field(s) define the word level error pattern (as defined in Section 15) to be injected in the transmission of each command word.
- SET GAPT y** This instruction directs the SURETEST to select the intermessage gap time defined in the value field **y**; as the default intermessage gap time to be inserted between the end of transmission of any BC simulator message, and the start of transmission of the subsequent BC simulator message. Should this instruction appear immediately following the definition of a specific message, the intermessage gap time defined by the value field **y** is selected for insertion between the end of transmission of that message, and the start of transmission of the next message. The definition of a time value of less than 10 uSec, or greater than 30 sec, will constitute an error.
- SET DAFB y** This instruction directs the SURETEST to, in the case of the bus selection for a controller simulator being both **bus A** and **bus B**, delay the transmission on **bus A** by the time defined in the value field **y**. The definition of a time value of less than 2 uSec, or greater than 30 sec, will constitute an error
- SET DBFA y** This instruction directs the SURETEST to, in the case of the bus selection for a controller simulator being both **bus A** and **bus B**, delay the transmission on **bus B** by the time defined in the value field **y**. The definition of a time value of less than 2 uSec, or greater than 30 Sec, will constitute an error
- SET RSPT y** This instruction directs the SURETEST to select the RT response time defined in the value field **y** for transmission of all responses subsequently defined for the 1553 RT simulator. The definition of a time value of less than 4 uSec, or greater than 19 uSec, will constitute an error

SET BEVT zzzz	This instruction directs the SURETEST to use the associated value field zzzz as the contents of the command word, which will cause the output of the simulated RT response whose definition follows the instruction.
SET STAT xxxxxxx	This instruction directs the SURETEST to define the contents of the 1553 status word to be transmitted, to be that contained in the least significant four hex digits of each of the value field xxxxxxx . The most significant three hex digits of each of the value field define the word level error pattern (as defined in Section 15) to be injected in the transmission of the status word.
SET MAXT y	This instruction directs the SURETEST to use the associated value field y as the length of time (in seconds) the host computer is to wait, after an INX command is sent, and the external trigger has not been received, before an error is indicated.

15.4 COMMANDS THAT GENERATE SURETEST RESPONSES

All SURETEST responses to MATE host computer instructions will appear as ASCII text. The allowable character set will be limited to upper case alphas, numerics, ., :, +, -, (,), **CR** and **LF**. All hexadecimal characters will be represented as ASCII numerics (0-9). All response words will be separated by a <sp>. All responses will be terminated by a **CR LF**. All responses must begin with either a <sp>, or an **F**.

Each response will be limited to 288 characters in length. Each character will appear as binary encoded ASCII with the most significant bit set to logic 0.

The SURETEST must respond to the following seventeen CIIL instructions:

STA	If there are unreported errors, the SURETEST must return an error response.
INX CONL	The SURETEST must return a Status Normal response unless an unreported error condition exists, in which case the error will be reported.
INX MONL	The SURETEST must return a Maximum Time response unless the unreported error condition exists, in which case the error shall be reported. This response is to indicate the maximum time (in seconds) that the MATE host computer is to wait for a SURETEST response to the next FTH..... instruction. This value will be the sum of the 1553 bus trigger event maximum time SET EVMT y , plus the external trigger qualifier maximum time (if specified) SET MAXT y , plus the gate width time SET GAWD y , plus any SURETEST data processing and response formatting time from the completion of the gate width timer.
INX SONL	The SURETEST must return a Status Normal response unless an unreported error condition exists, in which case the error will be reported.

INX COMO	The SURETEST must return a Maximum Time response unless the unreported error condition exists, in which case the error shall be reported. This response is to indicate the maximum time (in seconds) that the MATE host computer is to wait for a SURETEST response to the next FTH..... instruction. This value will be the sum of the 1553 bus trigger event maximum time SET EVMT y , plus the gate width time SET GAWD y , plus any SURETEST data processing and response formatting time from the completion of the gate width timer.
INX SIMO	The SURETEST must return a Maximum Time response unless the unreported error condition exists, in which case the error shall be reported. This response is to indicate the maximum time (in seconds) that the MATE host computer is to wait for a SURETEST response to the next FTH..... instruction. This value will be the sum of the 1553 bus trigger event maximum time SET EVMT y , plus the external trigger qualifier maximum time (if specified) SET MAXT y , plus the gate width time SET GAWD y , plus any SURETEST data processing and response formatting time from the completion of the gate width timer.
INX COSI	The SURETEST must return a Status Normal response unless an unreported error condition exists, in which case the error will be reported.
INX CSMO	The SURETEST must return a Maximum Time response unless the unreported error condition exists, in which case the error shall be reported. This response is to indicate the maximum time (in seconds) that the MATE host computer is to wait for a SURETEST response to the next FTH..... instruction. This value will be the sum of the 1553 bus trigger event maximum time SET EVMT y , plus the external trigger qualifier maximum time (if specified) SET MAXT y , plus the gate width time SET GAWD y , plus any SURETEST data processing and response formatting time from the completion of the gate width timer.
FTH MSGC	If the bus trigger event has not occurred, and the event maximum time has expired, then the SURETEST must return a Time-out Error response. If an external qualifier has been selected, and the event has not occurred within the defined maximum time, the SURETEST must return a Max Time Error response. Otherwise, the SURETEST must return a value defining the number of complete messages captured by the bus monitor as a Message Count response.
FTH MSEM y	If the bus trigger event has not occurred, and the event maximum time has expired, then the SURETEST must return a Time-out Error response. If an external qualifier has been selected, and the event has not occurred within the defined maximum time, the SURETEST must return a Max Time Error response. If the requested message does not exist, the SURETEST must return a Sample Error response. Otherwise, the SURETEST must return a value defining the message level errors contained in the requested message as a Message Error response, where y is a positive integer indicating the message count after the Data-Retention-Trigger-Event.

FTH BUID y	If the bus trigger event has not occurred, and the event maximum time has expired, then the SURETEST must return a Time-out Error response. If an external qualifier has been selected, and the event has not occurred within the defined maximum time, the SURETEST must return a Max Time Error response. If the requested message does not exist, the SURETEST must return a Sample Error response. Otherwise, the SURETEST must return a string of values (separated by <SP>) defining the Bus ID(s) of the words in the requested message as a Bus ID response, where y is a positive integer indicating the message count after the Data-Retention-Trigger-Event.
FTH DATC y	If the bus trigger event has not occurred, and the event maximum time has expired, then the SURETEST must return a Time-out Error response. If an external qualifier has been selected, and the event has not occurred within the defined maximum time, the SURETEST must return a Max Time Error response. If the requested message does not exist, the SURETEST must return a Sample Error response. Otherwise, the SURETEST must return a value defining the number of data words in the requested message as a Data Word Count response, where y is a positive integer indicating the message count after the Data-Retention-Trigger-Event.
FTH GAPT y	Time in seconds.
FTH RSPT y	Up to two values of time in seconds.
FTH DATA y	If the bus trigger event has not occurred, and the event maximum time has expired, then the SURETEST must return a Time-out Error response. If an external qualifier has been selected, and the event has not occurred within the defined maximum time, the SURETEST must return a Max Time Error response. If the requested message does not exist, the SURETEST must return a Sample Error response. If no data word(s) exist in the requested message, the SURETEST must return FFFFFFF . Otherwise, the SURETEST must return the value(s) of the data word(s) contained in the requested message as a Sample Normal response, where y is a positive integer indicating the message count after the Data-Retention-Trigger-Event.
FTH STAT y	If the bus trigger event has not occurred, and the event maximum time has expired, then the SURETEST must return a Time-out Error response. If an external qualifier has been selected, and the event has not occurred within the defined maximum time, the SURETEST must return a Max Time Error response. If the requested message does not exist, the SURETEST must return a Sample Error response. If no status word(s) exist in the requested message, the SURETEST must return FFFFFFF . Otherwise, the SURETEST must return the value(s) of the status word(s) contained in the requested message as a Sample Normal response, where y is a positive integer indicating the message count after the Data-Retention-Trigger-Event.

15.5 RESPONSE MESSAGES

Status Normal <sp>

All messages, which contain no errors, will contain an ASCII space <sp> as the initial character, error messages will contain an **F** in this position.

Maximum Time yyyy

Where **yyyy** represents up to four ASCII characters, right justified.

BIT Failed **F07MBT00 (MOD): t**

Where **t** is the message **INTERNAL SELFTEST ERROR - - FOLLOWING FACILITY FAILED**: after this will come the name of the boards(s) which failed the **IST**.

Confidence Test Failed **F07MBT00 (MOD): t**

Where **t** is the message **INTERNAL CONFIDENCE TEST ERROR - - FOLLOWING FACILITY FAILED**: after this will come the name of the function(s) that failed the **CNF**.

Syntax Error **F07MBT00 (MOD): t**

Where **t** represents up to 60 characters of English text describing the syntax error. Examples of syntax errors are **NO BGN FOUND, INTEGER OUT OF RANGE, INVALID DATA WORDS** and **ILLEGAL TEST CLAUSE**.

Max Time Error **F06MBT00 (MOD): t**

Where **t** is either **EXTERNAL TRIGGER TIMEOUT (MAXT)** or **INTERNAL TRIGGER TIMEOUT (EVMT)**.

Sample Error **F05MBT00 (MOD): t**

Where **t** is **MESSAGE NUMBER DOES NOT EXIST**.

Sample Normal **xxxxxxx**

Where **xxxxxxx** represents up to 7 hex characters, right justified, to define the contents of the requested sample (command, data or status) word(s) and any 1553 word level errors associated with each word. The least significant 4 characters for each word define the word contents. The most significant 3 characters define the word level error pattern for that sample word as defined in Section 15. Multiple words for the requested sample appear in the same response, each separated by a <sp>.

Message Count **vvv**

Where **vvv** represents up to three ASCII integer characters, right justified, to define the number of complete messages from the trigger occurrence until the Monitor Bus Traffic table is full, or until the gate width timer completes, whichever comes first. The message in which the trigger occurs is considered message number 1.

Data Word Count **vv**

Where **vv** represents up to two ASCII integer characters, right justified, defining the number of data words in the requested message.

Bus ID *xx sp xx sp - - - xx*

Where **xx** represents up to two ASCII integer characters, right justified, defining the bus over which the Monitor received the words of the requested message (A or B)

Message Errors *xx*

Where **xx** represents up to two hex characters defining the message level error pattern for the requested message.

16 PROGRAMMING SURETEST (CIIL Instructions)

16.1 INTRODUCTION

This section contains explanations and examples of instructions that are used by the test module adapter (TMA) to set up and carry out the operations of SURETEST.

Control Interface Intermediate Language (CIIL) instructions are transmitted as American Standard Code for Information Interchange (ASCII) text and characters.

Refer to Sections D1 and D2 for information on CIIL instructions and language structure.

Refer to MATE-STD-2806763 for a full definition of Modular Automatic Test Equipment (MATE) CIIL language.

each transmission will be limited to 8,000 characters in length. Each character will appear as binary encoded ASCII with the most significant bit set to logic 0. When MIL-STD-1553 data is being entered, only the 16 bits need to be specified (i.e. sync and parity are omitted from the CIIL string).

Each setup or individual message must be terminated with a carriage return (<cr>) and line feed (<lf>).

16.2 ALTERNATIVE LANGUAGE

To access the alternative language, use the **GAL** command (**G**o to **A**lternate **L**anguage) to quit MATE, and enter native Language.

16.3 ERROR BIT POSITIONS

This paragraph shows the bit positions of errors that can be injected into words, and detected in a received message, or which errors can be set for the monitor to trigger on.

16.3.1 Data formats.

Errors can be injected into both command and data words, the bit position of these errors to be injected are shown below:

Logic 0 in all imply no errors

Logic 1 = Bad Low High Inverted Insert Yes Yes
 * * * * * * *

Manchester Error Position	Parity	Bit Count	Bit Count	Sync	0	Manchester Error	Simultaneous Traffic	Invalid Word	Data
Bit 0 ~ 3	4	5	6	7	8	9	10	11	12 ~ 27

Error Bit Position of Data Formats.

16.3.2 Retrieved Messages

SURETEST will report any message level error detected, for the message being fetched, with the error bit positions defined as in below. The command **FTH MSEM y** gives this word for message number **y**.

Logic 0 in all imply no errors

Logic 1 = High * Low * Opposite * No-resp * Early * Late * High * Low *

Inter Message Gap	Inter Message Gap	Response Time	Response Time	Response Time	Response Time	Word Count	Word Count
Bit 0	1	2	3	4	5	6	7

Message Errors Retrieved.

16.3.3 Monitor Triggers

The Monitor shall trigger on errors as defined by modifier Bus-Event-Error (CIIL **BEVE**).

This modifier will be associated with a 16 bit data item, whose error bit position is shown in figure below:

Logic 0 in all imply no errors

Logic 1 implies trigger if error present.

Spare	Terminal Address	No Resp	Slow Resp	Both Buses	Wrong Bus	Word Count	Manchester	Word Length Long	Word Length Short	Parity
Bit 0 ~ 5	6	7	8	9	10	11	12	13	14	15

Monitor Trigger Errors.

16.4 Program Examples

Three sample programs using CIIL, along with an explanation of each command, are given, which illustrate how different setups, trigger events and fetch commands can be used for 1553 testing.

16.4.1 Sample CIIL program #1

Setup BC, RT and BM, use BM to monitor BC traffic on bus.

CIIL INSTRUCTION	EXPLANATION
FNC EXC INTE :CH0	This CIIL instruction tells SURETEST to prepare to accept electrical setup parameters
SET PROT T53B	This instructs SURETEST to select MIL-STD-1553B as the bus protocol.
SET XMTL 09	This defines output amplitude of all SURETEST messages to be 9V
FNC EXC CONL :CH0	Instructs SURETEST to accept subsequent instructions to set up electrical and protocol parameters for the Bus Controller.
SBF TCON	Instructs SURETEST to accept subsequent instructions to define configuration parameters of the Bus Controller (BC) simulator.
SET GAPT 1000E-6	Sets intermessage gap between BC messages to be 1000 uSec.
SET BUID AA	Instructs SURETEST to use the Primary Bus for bus traffic.
BGN EXCH	Defines the start of the BC subframe
BGN MESG	Allows for the setup of parameters of individual messages
SET COMD 80CC	Defines contents of the command word to be transmitted, with 80CC decoding to mean RT 10H subaddress 6 receive 12 data words. Note, that since this is only a four character hex word, no errors have been injected. If a sync error was to be injected here, the string would be set to SET COMD 01080CC
SET DATA A B C D E F C 0 F F E E	These are twelve items of data to be sent in the BC message.
END MESG	Completes definition of this message.
END EXCH	Completes definition of this subframe.
<cr>, <lf>	Terminates the BC clause
FNC EXC SONL :CH0	Instructs SURETEST to accept subsequent instructions to set up electrical and protocol for Remote Terminals (RT).
SBF TSIM	Instructs SURETEST to accept subsequent instructions to define configuration parameters of Remote Terminal (RT) simulator.
SET XMTL 9	Defines the output amplitude of all RT messages to be 9 V.
SET BUID CO	Instructs the RTs to receive/transmit 1553 messages, on the same bus it received the command from.
SET RSPT 08E-6	The RT response time is set to 8 uSec.
SET BEVT 80CC	The command (80CC) informs the simulator about which remote terminal and subaddress to enable; whether to transmit or receive, and how many words it can expect to be involved in the transfer.

CIIL INSTRUCTION	EXPLANATION
BGN EXCH	This defines the start of the RT subframe.
BGN MMSG	This allows for the setup of parameters of individual messages.
SET STAT 8000	The status word is set for this RT as 8000 (Remote Terminal 10H responds with no flags set).
END MMSG	Completes the definition of this message.
END EXCH	Completes the definition of this subframe.
<cr>, <lf>	Terminates the simulate clause (no more parameters will be accepted for the RT from now on).
FNC EXC MONL :CH0	Instructs SURETEST to accept subsequent instructions to set up electrical and protocol for the Bus Monitor.
SBF TMON	Instructs SURETEST to accept subsequent instructions to define configuration parameters of the Bus Monitor.
SET BEVD 000C	Tells the Bus Monitor to begin monitoring the bus traffic when data word 000C occurs (could be written as C, as all data right justified).
SET MASK FFFF	The word FFFF masks out all of the previous data word (C) so therefore any data word will trigger the monitor to capture data from the bus.
SET EVMT 1	This watchdog timer allows one second after the INX CSMO command for the trigger (any data word) to be activated, otherwise a timeout will be reported.
SET GAWD 0.5	The gate width is set for 0.5 seconds. After the trigger is activated, traffic is captured on the bus for 0.5 seconds (with resolution of +/- 5 uSec).
<cr>, <lf>	Terminates the monitor clause.
INX CSMO <cr>, <lf>	This initializes all sub-functions defined by the previous configuration clauses.
FTH MSEM 1 <cr>, <lf>	This instruction from the host computer requests SURETEST to return the message error mask (in this case the result is 1, indicating the intermessage gap is high).
FTH MSGC 390 <cr>, <lf>	SURETEST is instructed to return the message count of 390 (+/- 1) and therefore 390 complete messages will be captured with the gate width defined.
FTH COMD 100 <cr>, <lf>	SURETEST is instructed to return the command word that was in the 100 th message (in this case 80CC, since the same command word was transmitted every time).
FTH GAPT 389 <cr>, <lf>	SURETEST is instructed to return the gap time between 389 th message and the next message(999E-6 Secs in this example, 1E-6 Sec error due to resolution of internal clock on SURETEST).

16.4.2 Sample CIIL program #2

Use of the external trigger function

CIIL INSTRUCTION	EXPLANATION
SET XTML 20	This defines the output amplitude of all BC messages to be 20V.
SET SFRI 1000E-6	Sets length between each subframe to be 1000 uSec.
SET CRCC	Sets to transmit this BC message continuously.
BGN EXCH	Defines the start of the BC subframe.
BGN MMSG	Allows setup of individual message parameters.
SET COMD 0822	Defines contents of command word to be transmitted.
SET DATA 80ABCD 1234	Defines two data words to be sent, first (ABCD) with parity error injected, second (1234) with no errors.
END MMSG	Completes definition of this message.
END EXCH	Completes definition of this subframe.
SBF TSIM	Instructs SURETEST to accept subsequent instructions to define configuration parameters of the Bus Monitor.
SET BUID CO	Instructs the RTs to receive/transmit 1553 messages, on the same bus it received the command from.
SET RSPT 08E-6	The RT response time is set to 8 uSec.
SET BEVT 0822	The command (0822) informs the simulator about which remote terminal and subaddress to enable; whether to transmit or receive, and how many words it can expect to be involved in the transfer.
BGN EXCH	This defines the start of the RT subframe.
BGN MMSG	This allows for the setup of parameters of individual messages.
SET STAT 0800	The status word is set for this RT as 0800 (Remote Terminal 01 responds with no flags set).
END MMSG	Completes definition of this message.
END EXCH	Completes definition of this subframe.
<cr>, <lf>	Terminates the simulate clause.
FNC EXC INTE :CH0	This CIIL instruction tells SURETEST to prepare to accept electrical setup parameters
SET PROT T53B	This instructs SURETEST to select MIL-STD-1553B as the bus protocol.
<cr>, <lf>	Terminates the Bus-Test-Setup clause.
FNC EXC CSMO :CH0	Instructs SURETEST to accept subsequent instructions to set up electrical and protocol for the Bus Controller and Bus Monitor and remote Terminals, dependant on subfunction defined.

CIL INSTRUCTION	EXPLANATION
SBF TCON	Instructs SURETEST to accept subsequent instructions to define configuration parameters of the Bus Controller (BC) simulator.
SET GAPT 3E-3	Sets intermessage gap between BC messages to be 3 milliseconds.
SET BUID BB	Instructs SURETEST that 1553 messages will be on the secondary bus.
SBF TMON	Instructs SURETEST to accept subsequent instructions to define configuration parameters of the Bus Monitor.
SET POTW 122	Instructs the monitor to receive 122 words after the trigger has been activated.
SET BEVA 0000	Instructs the monitor to trigger on any word of the pattern 0000.
SET MASK FFFF	The mask is set to trigger on any pattern, with all masking bits set (the first 122 words will be captured as the trigger is any word).
SET EVMT 3	This watchdog timer allows three seconds after the EXT TRIG command for the trigger (any word) to be activated, otherwise a timeout error will be reported.
SET GAWD 3	The gate width is set for 3 seconds. After the trigger is activated, traffic is captured on the bus for 3 seconds, or until POTW is reached, whichever is the shorter.
SET TRSC EXT	This allows SURETEST to trigger on the occurrence of an external trigger pulse.
SET TRLV 4E-1	The external trigger threshold level is set to 0.4V.
SET TRSL NEG	The external trigger will have negative slope (bus event will trigger on falling edge at 0.4V).
SET MAXT 10	Allows 10 seconds for the external trigger to occur after the INX CSMO command is sent.
<cr>, <lf>	Terminates all setup clauses.
INX CSMO <cr>, <lf>	This initializes all sub-functions defined by the previous configuration clauses. The external trigger has to be activated within 10 Secs, or timeout error will be reported. When capture complete, following data may be retrieved.
FTH DATA 1 <cr>, <lf>	This instruction from the host computer requests SURETEST to return all the data words contained in the first message (in this example would be 81ABCD and 1234, note that the invalid word bit is set in the erroneous data word).

16.4.3 Sample CIIL program #3

Use of the Superseding Command

CIIL INSTRUCTION	EXPLANATION
FNC EXC INTE :CH0	This instruction tells SURETEST to prepare to accept electrical setup parameters
SET PROT T53B	This instructs SURETEST to select MIL-STD-1553B as the bus protocol for all subsequent transmissions.
SET XMTL 09	This defines output amplitude of all SURETEST BC messages to be 9V
<cr>, <lf>	Transmits the BC setup to the host computer.
FNC EXC CONL :CH0	Instructs SURETEST to accept subsequent instructions to set up electrical and protocol for the Bus Controller.
SBF TCON	Instructs SURETEST to accept subsequent instructions to define configuration parameters of the Bus Controller (BC) simulator.
SET XMTL 15	This defines output amplitude of all messages to be 15V
SET GAPT 1E-3	Sets intermessage gap between BC messages to be one millisecond.
SET BUID AB	Instructs SURETEST that 1553 messages will be on the primary or secondary bus.
SET CRCC	Sets to transmit this BC message continuously.
BGN EXCH	Defines the start of the BC subframe.
SET BUID AB	Instructs SURETEST to accept the initial command on the secondary bus, then receive a superseding command on the primary bus (since only one command specified, then superseding command is the same as the original command).
SET DAFB 100E-6	The superseding command on the primary bus is delayed in time from the original command on the secondary bus by 100 uSec.
BGN MESG	Allows for the setup of parameters of individual messages
SET COMD 80CC	Defines contents of the command word to be transmitted, with 80CC decoding to mean RT 10H subaddress 6 receive 12 data words
SET DATA A B C D E F C 0 F F E E	These are twelve items of data to be sent in the BC message.
END MESG	Completes definition of this message.
END EXCH	Completes definition of this subframe.
<cr>, <lf>	Transmits BC setup to the host computer.

CIIL INSTRUCTION	EXPLANATION
FNC EXC MONL :CH0	This instruction tells SURETEST to prepare to accept electrical and protocol setup parameters for the Bus Monitor.
SBF TMON	Instructs SURETEST to accept subsequent instructions to define configuration parameters of the Bus Monitor.
SET BEVD C	Tells the Bus Monitor to begin monitoring the bus traffic when data word C occurs.
SET MASK FFFF	The word FFFF masks out all of the previous data word (C) so therefore any data word will trigger the monitor to capture data from the bus.
SET EVMT 1	This watchdog timer allows one second after the INX CSMO command for the trigger (any data word) to be activated, otherwise a timeout will be reported.
SET GAWD 3E-2	The gate width is set for 30 milliseconds. After the trigger is activated, traffic is captured on the bus for 30 milliseconds (with resolution of +/- 5 uSec).
<cr>, <lf>	Transmits the BM setup to the host computer.
INX CSMO <cr>, <lf>	This initializes the transmission of messages from the BC and BM sub-functions defined by the previous configuration clauses.
FTH BUID 1 <cr>, <lf>	This instruction from the host computer requests SURETEST to return which bus the message was transmitted on, in this example it is BB BB BB BB BB BB BB BB BB BB BB BB BB.
FTH BUID 2 <cr>, <lf>	This instruction from the host computer requests SURETEST to return which bus the message was transmitted on, in this example it is AA AA AA AA AA AA AA AA AA AA AA AA AA AA AA AA.
FTH DATA 4 <cr>, <lf>	This instruction from the host computer requests SURETEST to return all the data words contained in the fourth message, which in this example would be A B C D E F C 0 F F E E.