

# IIB-429-VME-4C

# ARINC-429 Controller VMEbus 8 Transmit and 8 Receive Channels

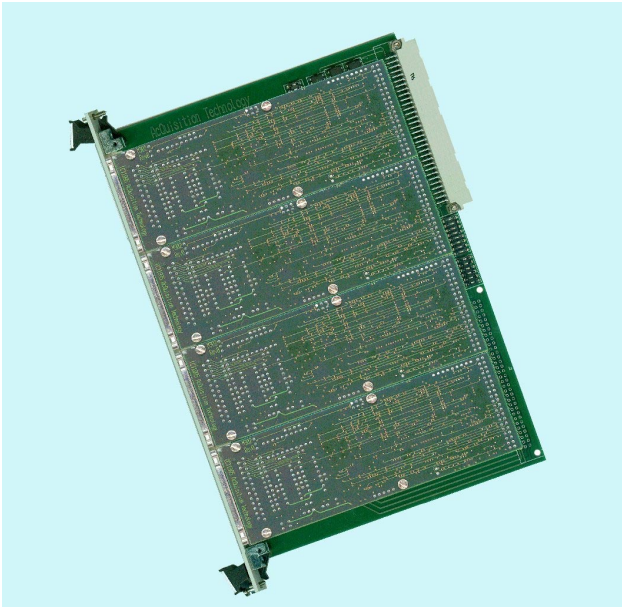

## Functional Description

The IIB-429-VME-4C provides 16 ARINC-429 compatible channels (8 receive and 8 transmit) at any rate between 12.5 and 100 kbps.

Because the IIB-429-VME-4C is built upon a flexible platform, user functions can be implemented almost without restriction, making this product flexible and user-friendly.

This VMEbus board has a 6U form factor.

This VME unit is also available in a 3U form factor, as IIB-429-VME.

## Technical Features

- Flexible platform allows easy addition of user-specific requirements
- Eight transmit and eight receive channels
- Supports standard (8-bit) and extended labels (10-bit)
- Adjustable data rate from 12.5 to 100kbps
- 16 user selectable labels for interrupt generation upon reception
- Status and statistics monitoring for all channels
- ARINC-429 rise/fall capacitors selectable per channel
- Provides excellent platform for ARINC-429 protocol analysis

## Technical Details

### Controller:

The onboard MC68332 32-bit CPU executes firmware from local Flash memory, providing a versatile and user-friendly ARINC-429 interface

### Receiving Data:

For each receive channel, a local buffer is available for each label. After its parity is checked, the received message is stored in the corresponding label buffer, overwriting the previous content. The last received message for a specific label can be retrieved, by issuing a command from the host to the firmware interface, specifying the channel and label required.

### Transmitting Data:

A message is transmitted by passing it as a parameter to the command interface, and initiate the transmit by issuing the appropriate command. Parity generation and checking is done transparently to the user.

### Interrupt Facilities:

The user can select up to 16 labels per channel for interrupt generation upon reception of new data. This feature provides a mechanism that allows a user to monitor a label without data-loss.

### Statistics:

For each channel and for each label, the numbers of transmitted and received messages are logged into the statistics part of the local firmware. Parity errors are logged globally to a channel.

### VMEbus Interface:

The VMEbus slave interface of the IIB-429-VME-4C is compliant with the VMEbus Specification Rev C.1. It supports standard or short addressing (A24/A16), D16/D08 (EO) data transfer capabilities and configurable interrupt level (I(x)).

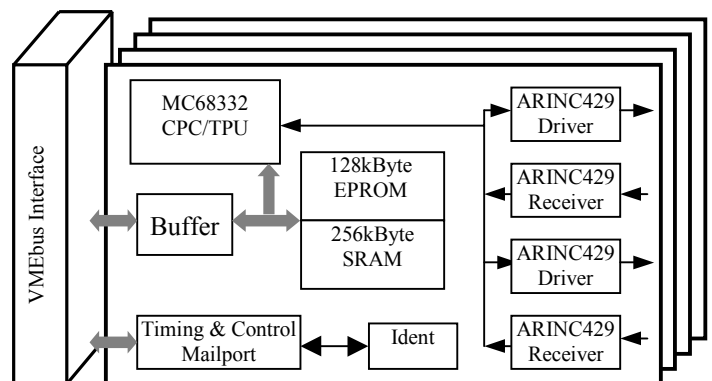

## Ordering Information

- IIB-429-VME-4C/0T8R** IIB-429-VME-4C, no Xmit, 8x Recv
- IIB-429-VME-4C/4T0R** IIB-429-VME-4C, 4x Xmit, no Recv
- IIB-429-VME-4C/4T8R** IIB-429-VME-4C, 4x Xmit, 8x Recv
- IIB-429-VME-4C/8T0R** IIB-429-VME-4C, 8x Xmit, no Recv
- IIB-429-VME-4C/8T8R** IIB-429-VME-4C, 8x Xmit, 8x Recv
- IIB-429-VME-4C/SW** APIS based software
- IIB-429-VME-4C/MAN** IIB-429-VME-4C manual on paper

Product Data Sheet  
Product: IIB-429-VME-4C  
PDS: IIB-429-VME-4C Rev 1  
Date: April 2004

Western Avionics Ltd  
13/14 Shannon Free Zone  
Co. Clare  
Ireland

Tel: +353-61-472233  
Fax: +353-61-471675  
Email: sales@western-av.com  
URL: www.western-av.com

